

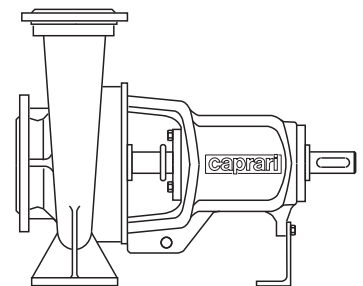

NORM SINGLE-STAGE PUMPS - EN733
(DIN 24255)
*НОРМАЛИЗОВАННЫЕ ОДНОСТУПЕНЧАТЫЕ
НАСОСЫ - EN733 (DIN 24255)*
**POMPE MONOGIRANTI
NORMALIZZATE - EN733 (DIN 24255)**

NC



caprari

pumping power

ISO 9001
ISO 14001
ISO 45001

BUREAU VERITAS
Certification



• Technical data <i>Технические данные</i> Dati tecnici	3
• Pump coding <i>Пояснения к обозначениям</i> Esemplificazione sigla	4
• Performance ranges <i>Диапазоны рабочих параметров</i> Campi di prestazione	5
• Performance ranges - Operating limits <i>Диапазоны рабочих параметров - Рабочие ограничения</i> Campi di prestazione - Limiti di funzionamento	6
• Pump construction and materials <i>Конструкция и материалы насоса</i> Costruzione pompa e materiali	7
• Technical data standardized enclosed electric motors <i>Технические данные нормализ. закрытых электродвигателей</i> Dati tecnici motore elettrico chiuso normalizzato	8
• Performances curves at 950 n [min-1] <i>Рабочие характеристики при 950 об. [мин-1]</i> Caratteristiche di funzionamento a 950 n [min-1]	9
• Performances curves at 1450 n [min-1] <i>Рабочие характеристики при 1450 об. [мин-1]</i> Caratteristiche di funzionamento a 1450 n [min-1]	13
• Performances curves at 2900 n [min-1] <i>Рабочие характеристики при 2900 об. [мин-1]</i> Caratteristiche di funzionamento a 2900 n [min-1]	42
• Overall dimensions and weights <i>Общие габариты и вес</i> Dimensioni di ingombro e pesi	56
• Selection - Dimensions and weights for base mounted electric pumps 2P / 50Hz <i>Подбор - Габариты и вес электронасосов на раме 2P / 50Hz</i> Selezione - Dimensioni e pesi elettropompe su base 2P / 50Hz	58
• Selection - Dimensions and weights for base mounted electric pumps 4P / 50Hz <i>Подбор - Габариты и вес электронасосов на раме 4P / 50Hz</i> Selezione - Dimensioni e pesi elettropompe su base 4P / 50Hz	61
• Selection - Dimensions and weights for base mounted electric pumps 6P / 50Hz <i>Подбор - Габариты и вес электронасосов на раме 6P / 50Hz</i> Selezione - Dimensioni e pesi elettropompe su base 6P / 50Hz	65
Flanges (UNI EN 1092-2) - <i>Фланцы (UNI EN 1092-2)</i> - Flange (UNI EN 1092-2)	66

GENERAL INFORMATION

Single-stage horizontal shaft pumps with main dimensions and characteristics conforming to EN733 (DIN 24255) standards.

- Pump casing: volute type with flanged delivery port.
- Impeller: high efficiency closed type with balanced axial thrust.
Available in either cast iron or AISI 316 stainless steel/bronze
- Shaft and supports:
the AISI 420 stainless steel shaft (fully protected against contact with the pumped water) is guided and supported by two ball bearings housed in the connecting support that are permanently lubricated with high quality grease to guarantee longer life.
The wide safety margin considered when sizing the support, the shaft and the bearings allows the pump to be coaxially coupled to both electric motors and internal combustion engines.
- Seal:
the mechanical type, housed in the connecting support and easily replaceable.
- Coupling to the motor
the NC series pumps can be coupled to IP 55 standard electric motors with B3 motor mounting. The pumps can be coupled to high-efficiency motors. The BACK PULL OUT constructional concept, connection to the motor with a flexible coupling and spacer, available on request, allow the wet end to be disassembled from the rear for inspection purposes and repairs without disconnecting the motor or the pump casing from the piping.
- Direction of rotation:
clockwise viewed from drive side.
- Port positioning: axial for suction / radial delivery port pointing upwards.

APPLICATIONS

The NC series standardized pumps have been designed for several applications, such as fire-fighting, industrial water supply, industrial uses, anti-frost protection, irrigation, medium and large heating and air conditioning systems and water supply for both civil and industrial uses.

LIMITS

- Max. temperature of pumped liquid: +90°C (special versions on request +140°C)
- Min. temperature of pumped liquid: -10°C.
- Max operating time with closed discharge and liquid at 90°C: 30 sec.
- Nominal pressure 10/16 bar (with flanging conforming to UNI 2223 PN16/PN25).
- Maximum content of solids, the same hardness and granulometry of silt: 50 [g/m³]
- The pumps can operate with all fluids chemically and mechanically compatible with the pump materials.

Special versions can be supplied on request.

NOTE:

Upon request the curves NPSH are available until 16 m for 2-pole electric pumps.

ХАРАКТЕРИСТИКИ

Одноступенчатые насосы с горизонтальной осью, основные характеристики и размеры которых соответствуют стандартам EN733 (DIN 24255).

- Корпус насоса: спиральный с фланцевым подающим патрубком.
- Рабочее колесо: закрытого типа с высоким КПД, с балансировкой осевой силы.
Доступны в исполнении из чугуна или нержавеющей стали AISI 316/бронзы.
- Вал и опоры:
вал из нержавеющей стали AISI 420 (полностью защищенный от контакта с перекачиваемой водой) направляется и поддерживается двумя шарикоподшипниками, размещенными в соединительной опоре, с высококачественной постоянной смазкой, что гарантирует более длительный срок службы.
Большой запас прочности, предусмотренный при расчете размеров опоры, вала и подшипников, позволяет осуществлять соосное соединение как с электродвигателями, так и с ДВС.
- Уплотнение:
механического типа, размещенное в соединительной опоре и легко заменяемое.
- Соединение с двигателем:
насосы серии NC могут соединяться со стандартными электродвигателями IP 55 конструкции B3; насосы могут соединяться с двигателями высокой эффективности.
Конструкция BACK PULL OUT и соединение с двигателем с помощью эластичной муфты и прокладки под заказ позволяют демонтировать сзади гидравлическую часть для осмотра или ремонта, не отсоединяя двигатель и корпус насоса от трубы.
- Направление вращения:
по часовой стрелке, если смотреть со стороны привода.
- Ориентация патрубков: всасывающий - осевая / напорный - радиальная, ориентация вверх.

ПРИМЕНЕНИЕ

Нормализованные насосы серии NC предназначены для таких применений, как противопожарная защита, промышленные водопроводы, защита от обледенения, орошение, средние и крупные системы отопления и кондиционирования, а также питьевого водоснабжения в гражданском и промышленном секторе.

ОГРАНИЧЕНИЯ ПРИМЕНЕНИЯ

- Макс. температура перекачиваемой жидкости: +90°C (по запросу +140°C)
- Мин. температура перекачиваемой жидкости: -10°C
- Макс. время работы при закрытом патрубке с температурой жидкости 90°C: 30 сек.
- Номинальное давление 10/16 бар (с фланцами в соответствии с UNI 2223 PN16/PN25)
- Макс. содержание твердых веществ с твердостью и гранулометрией ила: 50 [г/м³]
- Возможность перекачки всех жидкостей, химически и механически совместимых с конструкционными материалами насосов.

Под заказ могут быть предоставлены специальные исполнения.

ПРИМЕЧАНИЕ:

Под заказ доступны кривые с NPSH 16 м для 2-полюсных электронасосов.

CARATTERISTICHE

Pompe monogiranti ad asse orizzontale con caratteristiche e dimensioni principali secondo le norme EN733 (DIN 24255).

- Corpo pompa: del tipo a voluta con bocca premente flangiata.
- Girante: del tipo chiuso ad elevato rendimento, con equilibratura della spinta assiale.
Disponibile in ghisa o acciaio inox AISI 316/bronzo.
- Albero e supporti:
l'albero in acciaio inossidabile AISI 420, (totalmente protetto dal contatto con l'acqua pompata) è guidato e sostenuto da due cuscinetti a sfere alloggiati nel supporto di collegamento e lubrificati a grasso permanente di alta qualità a garanzia di una più lunga durata.
L'ampio margine di sicurezza tenuto nel dimensionare il supporto, l'albero ed i cuscinetti, consente l'accoppiamento coassiale sia a motori elettrici che endotermici.
- Tenuta:
di tipo meccanico alloggiata nel supporto di collegamento e facilmente sostituibile.
- Accoppiamento al motore
le pompe serie NC, possono essere accoppiate a motori elettrici standard IP 55 in forma costruttiva B3; le pompe possono essere accoppiate a motori ad alto rendimento.
Il concetto costruttivo BACK PULL OUT e l'accoppiamento al motore con giunto elastico e distanziale spaziatore su richiesta consentono lo smontaggio posteriore della parte idraulica per l'ispezione o la riparazione, senza sconnettere il motore ed il corpo pompa dalle tubazioni.
- Senso di rotazione:
orario visto dal lato comando.
- Orientamento bocche: aspirante assiale / premente radiale rivolta verso l'alto.

APPLICAZIONI

Le pompe normalizzate serie NC sono state studiate per i settori di utilizzo quali antincendio, acquadottistica, industriale, antibrina, irrigazione, impianti di riscaldamento e condizionamento di medie e grandi dimensioni e approvvigionamento idrico sia ad uso civile che industriale.

LIMITI D'IMPIEGO

- Temperatura max. liquido sollevato: +90°C. (esecuzione su richiesta +140°C.)
- Temperatura min. liquido sollevato: -10°C.
- Tempo max di funzionamento a bocca chiusa con liquido a 90°C.: 30 sec.
- Pressione nominale 10/16 bar (con flangiature secondo UNI 2223 PN16/PN25).
- Contenuto massimo di sostanze solide della durezza e granulometria del limo: 50 [g/m³].
- Possibilità di veicolamento di tutti quei liquidi chimicamente e meccanicamente compatibili con i materiali costruttivi delle pompe.

Su richiesta possono essere fornite esecuzioni speciali.

NOTA:

Su richiesta sono disponibili curve con NPSH a 16m per le elettropompe a 2 poli.

PUMP CODING
Пояснения к обозначениям
ESEMPLIFICAZIONE SIGLA

Code - Обозначение - Sigla
NC100-315/. - NCF100-315/. - NCH100-315/. - NCHF100-315/.

Series NC (with Cast Iron impeller)
Серия NC (с раб. колесом из серого чугуна)
Serie NC (con girante in ghisa) _____ **NC**

Series NCF (with AISI 316 stainless steel impeller/bronze)
Серия NCF (с раб. колесом из нержав. стали AISI 316/бронзы)
Serie NCF (con girante in acciaio inox AISI 316/bronzo) _____ **NCF** **100** - **315** **/.**

Series NCH (High pressure) - _____ **NCH**
Серия NCH (Высокое давление) - Serie NCH (Alta pressione)

Series NCHF (High pressure) (with AISI 316 stainless steel impeller) - _____ **NCHF**
Серия NCHF (Высокое давление) (с раб. колесом из нержав. стали) -
Serie NCHF (Alta pressione) (con girante in acciaio inox AISI 316)

Nominal diameter (mm) of delivery port -
Номин. диаметр (мм) выходного патрубка - Diametro nominale (mm) bocca premente _____

Impeller diameter (mm) - Диаметр раб. колеса (мм) - Diametro girante (mm) _____

Executions on demand - Исполнение под заказ - Esecuzioni a richiesta _____

MECHANICAL SEAL

МЕХ. УПЛОТНЕНИЕ

TENUTA MECCANICA

Type Тип Tipo	Component / Particulier / Particolare			
	Ressort Пружина Molla	Joints Уплотнения Guarnizioni	Static seat Неподвиж. кольцо Anello fisso	Rotatic seat Вращающ. кольцо Anello rotante
Material/ Материал / Materiale				
Standard	AISI 316	EPDM	SILICON CARBIDE CARBURE DE SILICIUM CARBURO DI SILICIO	SILICON CARBIDE CARBURE DE SILICIUM CARBURO DI SILICIO

PUMPED LIQUID

Conforming to : DIN 24960 - ISO 3069.

TOLERANCES

Service conditions have been measured with cold water (15°C - 59°F) at 1 bar atmospheric pressure. These tolerances are guaranteed with standard assembly line pumps built according to UNI/ISO 9906 Grade 3B. Catalogue data are for liquids with a density of 1 kg/dm³, and kinematic viscosity not exceeding 1 mm²/s. If requested the pump can be tested according to UNI/ISO 9906 Grade 2B standards.

REGULATIONS

Parameters not covered by EN733 (DIN24255):

1450 rpm
32-250, 40-315, 80-400, 150-500, 200-400

2900 rpm
32-250, 50-315, 100-315, 125-250

ПЕРЕКАЧИВАЕМАЯ ЖИДКОСТЬ

Стандарт: DIN 24960 - ISO 3069.

ДОПУСКИ

Рабочие характеристики измерялись с использованием холодной воды (15°C) при атмосферном давлении (1 бар). Поскольку речь идет о серийно производимых насосах, они гарантированы на соответствие стандарту UNI/ISO 9906 Уровень 3B. Данные каталога относятся к жидкостям с плотностью 1 кг/дм³ и кинематической вязкостью не более 1 мм²/с. Под заказ изделия могут быть протестированы в соответствии со стандартами UNI/ISO 9906 Уровень 2B.

НОРМАТИВЫ

Размеры, не предусмотренные в EN733 (DIN24255):
1450 об./мин.
32-250, 40-315, 80-400, 150-500, 200-400
2900 об./мин.
32-250, 50-315, 100-315, 125-250

LIQUIDO DA SOLLEVARE

Secondo le norme : DIN 24960 - ISO 3069.

TOLLERANZE

Le caratteristiche di funzionamento sono state rilevate con acqua fredda (15°C) alla pressione atmosferica (1bar) e vengono garantite, trattandosi di pompe costruite in serie, secondo le norme UNI/ISO 9906 grado 3B. I dati di catalogo si riferiscono a liquidi con densità di 1kg/dm³ e con viscosità cinematica non superiore a 1mm²/s. Su richiesta, possono essere collaudate secondo le norme UNI/ISO 9906 grado 2B.

NORMATIVE

Grandezze non previste in EN733 (DIN2455):

1450 rpm
32-250, 40-315, 80-400, 150-500, 200-400
2900 rpm
32-250, 50-315, 100-315, 125-250

Performance ranges
 Диапазон рабочих параметров
 Campi di prestazione

Performance curves at 2900 n [min⁻¹] / Рабочие характеристики при 2900 об. [мин.-1] / Caratteristiche di funzionamento a 2900 n [min⁻¹]

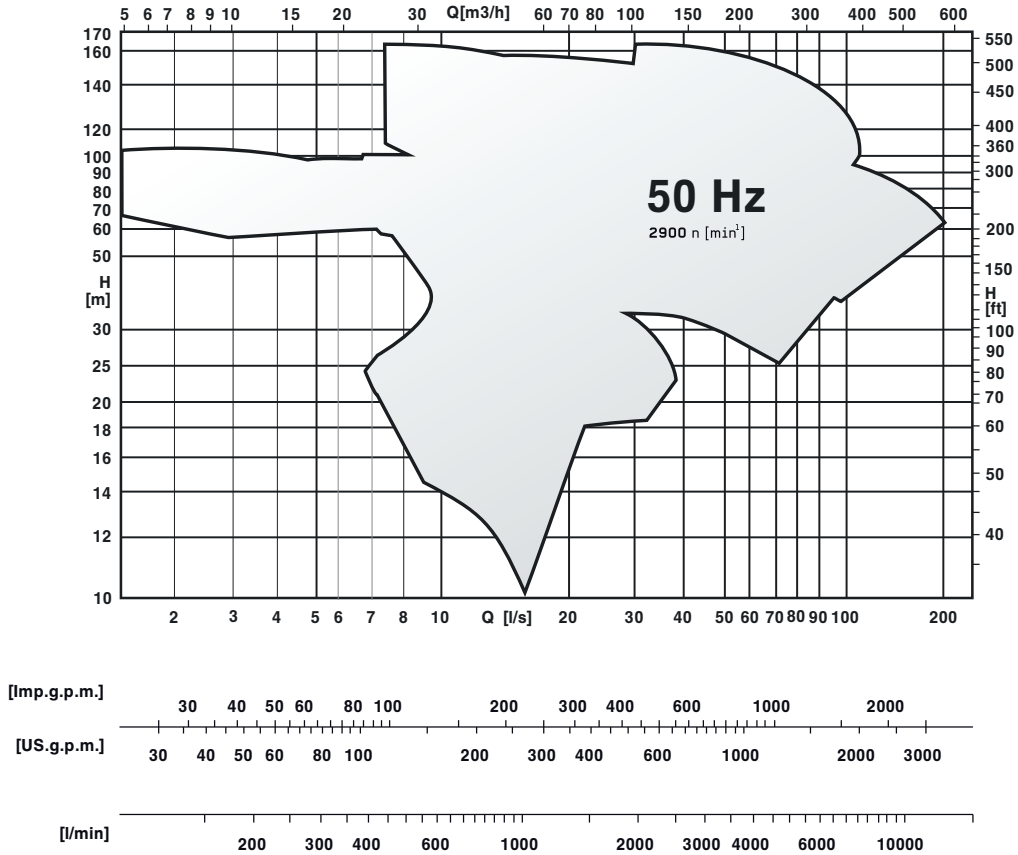

Performance curves at 1450 n [min⁻¹] / Рабочие характеристики при 1450 об. [мин.-1] / Caratteristiche di funzionamento a 1450 n [min⁻¹]

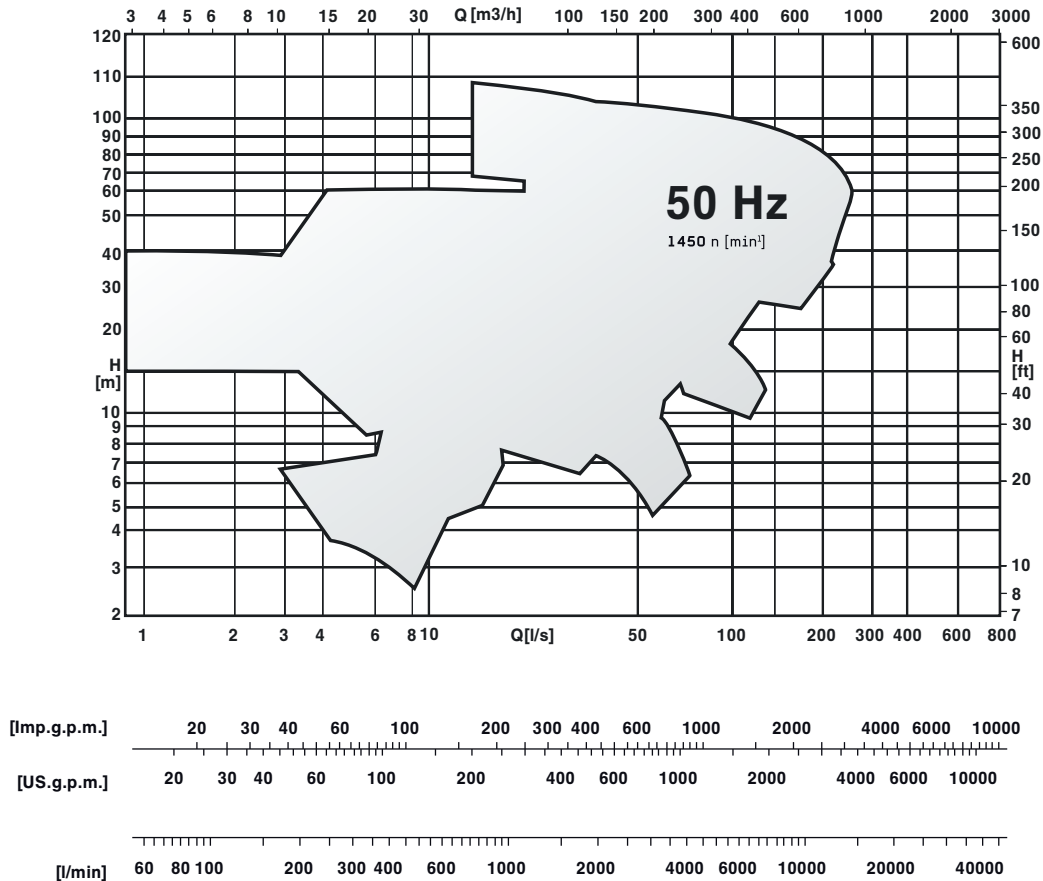

*Parameters not covered by EN733 (DIN24255): see performance fields / Типоразмеры, не предусмотренные в EN733 (DIN24255): см. "Диапазон рабочих параметров" / Grandezze non previste in EN733 (DIN24255): vedi campi di prestazione

Performance ranges - Operating limits
 Диапазон рабочих параметров - Рабочие ограничения
 Campi di prestazione - Limiti di funzionamento

Performance curves at 950 n [min⁻¹] / Рабочие характеристики при 950 об. [мин⁻¹] / Caratteristiche di funzionamento a 950 n [min⁻¹]

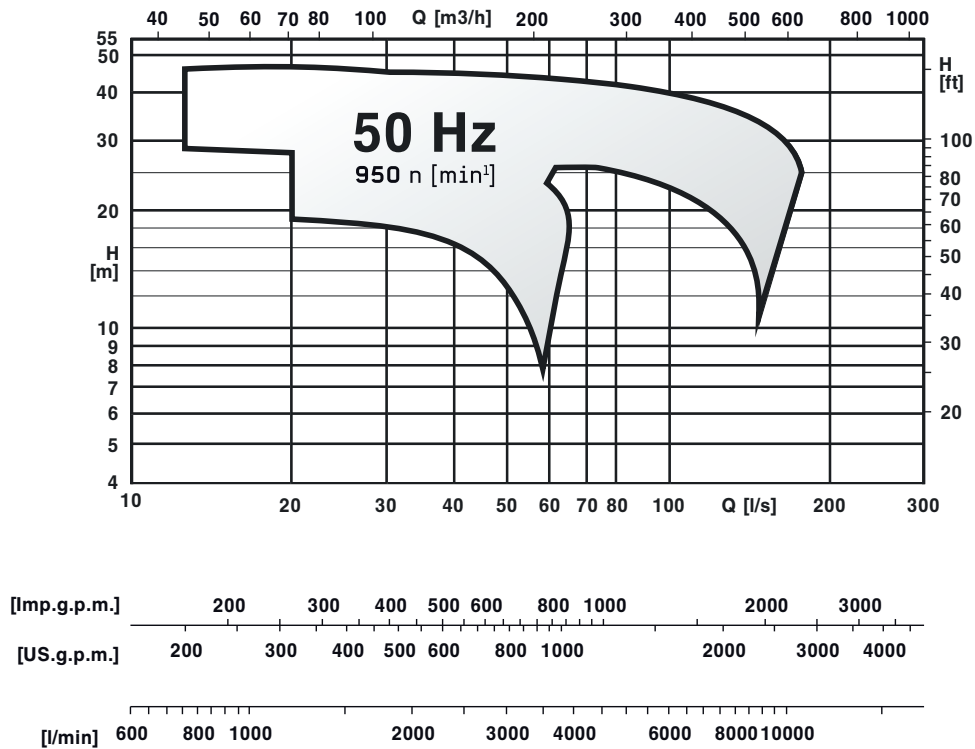

*Parameters not covered by EN733 (DIN24255): see performance fields / Типоразмеры, не предусмотренные в EN733 (DIN24255): см. "Диапазон рабочих параметров" / Grandezze non previste in EN733 (DIN24255): vedi campi di prestazione

OPERATING LIMITS / РАБОЧИЕ ОГРАНИЧЕНИЯ / LIMITI DI FUNZIONAMENTO

Maximum speed Макс. скорость Velocità massima	[min ⁻¹]
NC32-250	3500
NCF32-250	3500
NC40-250	3500
NCF40-250	3500
NC40-315	1750
NCF40-315	1750
NC50-125	3500
NCF50-125	3500
NC50-200	3500
NCF50-200	3500
NC50-250	3500
NCF50-250	3500
NCF50-315	1750
NC65-160	3500
NCF65-160	3500
NC65-200	3500
NCF65-200	3500
NC65-250	3500
NCF65-250	3500
NC65-315	1750
NCF65-315	1750
NCF80-200	3500
NC80-250	3500
NCF80-250	3500
NC80-315	1750
NCF80-315	1750
NC80-400	1750
NCF80-400	1750
NC100-200	3500

Maximum speed Макс. скорость Velocità massima	[min ⁻¹]
NCF100-200	3500
NC100-315	1750
NCF100-315	1750
NC100-400	1750
NCF100-400	1750
NCF125-200	3500
NC125-250	1750
NCF125-250	1750
NC125-315	1750
NCF125-315	1750
NC125-400	1750
NCF125-400	1750
NC150-250	1750
NCF150-250	1750
NC150-315	1750
NCF150-315	1750
NC150-400	1750
NCF150-400	1750
NC200-400	1750
NCF200-400	1750
NCH50-315	2900
NCHF50-315	2900
NCHF65-315	2900
NCH100-315	2900
NCHF100-315	2900
NCH125-250	2900
NCHF125-250	2900
NCH125-400	1750
NCHF125-400	1750

Maximum speed Макс. скорость Velocità massima	[min ⁻¹]
NCH125-500	1450
NCHF125-500	1750
NCH150-500	1450
NCHF150-500	1450
NCH200-500	1450
NCHF200-500	1750

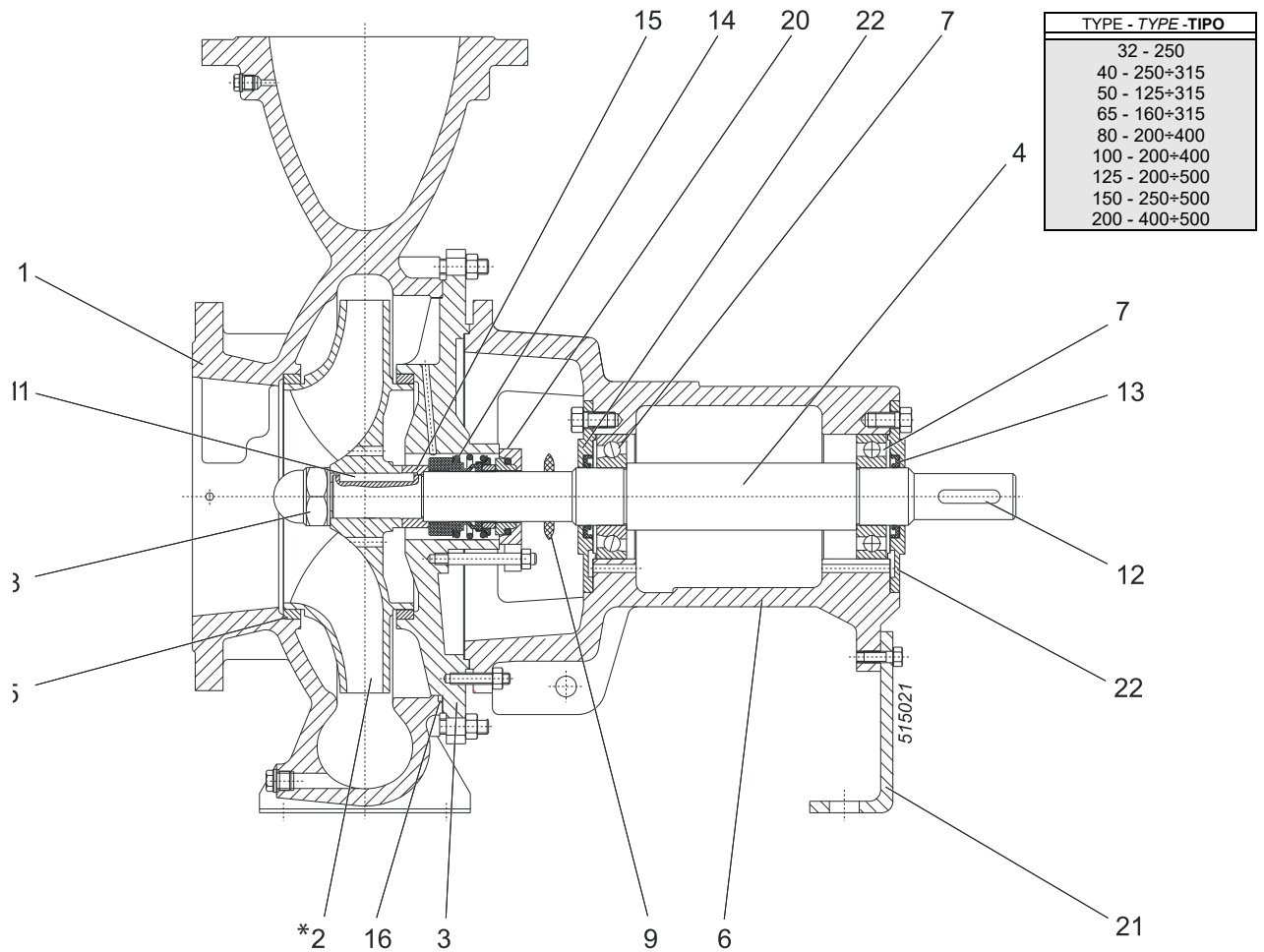

	Materials	Компонент	Material	Nomenclatura	Materiale
1	Cast iron	Корпус насоса	Серый чугун	Corpo pompa	Ghisa grigia
2*	Cast iron	Рабочее колесо	Серый чугун	Girante	Ghisa grigia
3	Cast iron	Соединительная опора	Серый чугун	Supporto di collegamento	Ghisa grigia
4	Stainless steel	Вал	Нержав. сталь	Albero	Acciaio inox
5°	Cast iron	Износное кольцо	Серый чугун	Anello sede girante	Ghisa grigia
6	Cast iron	Опора	Серый чугун	Supporto	Ghisa grigia
7	-	Подшипник	-	Cuscinetto	-
8	Stainless steel	Гайка	Нержав. сталь	Dado	Acciaio inox
9	Nitrile rubber	Отражатель воды	Резина нитрил	Anello para-acqua	Gomma nitrilica
11	Stainless steel	Шпонка	Нержав. сталь	Linguetta	Acciaio inox
12	Steel	Шпонка 2	Сталь	Linguetta 2	Acciaio
13	Nitrile rubber	Уплотнит. кольцо	Нитрил-резина	Anello di tenuta	Gomma nitrilica
14	Silicon carbide/silicon carbide/NBR	Мех. уплотнение	Карбид кремния/Карбид кремния/NBR	Tenuta meccanica	Carburo di silicio/ carburo di silicio/NBR
15	-	Втулка вала	-	Bussola albero	-
15	Stainless steel	Прокладка	Нержав. сталь	Distanziale	Acciaio inox
16	Nitrile rubber	Уплотнит. кольцо OR	Нитрил-резина	Anello di tenuta OR	Gomma nitrilica
20	-	Сальник	-	Premitreccia	-
20	Cast iron	Крышка мех. уплотнения	Серый чугун	Coperchio tenuta meccanica	Ghisa grigia
21	Steel	Опорная ножка	Сталь	Piede di sostegno	Acciaio
22	Cast iron	Крышка подшипника	Серый чугун	Coperchio cuscinetto	Ghisa grigia

Screws and nuts in stainless steel.

* In stainless steel AISI 316 / Bronze for the NCF.../...

° In NCF version with stainless steel impeller and bronze impeller seat ring, or with bronze impeller and stainless steel seat ring.

Винты и гайки из нержавеющей стали.

* Из нержав. стали AISI 316 / Бронза для вариантов NCF.../...

° В варианте NCF с раб. колесом из нержав. стали и опорного кольца раб. колеса из бронзы, или с раб. колесом из бронзы и опорным кольцом из нержав. стали.

Viti e dadi in acciaio inox

* In acciaio inox AISI 316 / Bronzo per versioni NCF.../...

° In versione NCF con girante in acciaio inox e anello sede girante in bronzo, oppure con girante in bronzo e anello sede in acciaio inox

Technical data standardized enclosed electric motors (Indicatives values according to the type of motor installed)
 Тех. данные стандартизированных закрытых электродвигателей (ориентировочные значения в зависимости от марки двигателя)
 Dati tecnici motore elettrico chiuso normalizzato (Valori indicativi in funzione della marca di motore utilizzato)

Motor power Мощность двигателя Potenza motore	2 Poles 50 Hz 2 Полюса 50 Гц 2 Poli 50 Hz			4 Poles 50 Hz 4 Полюса 50 Гц 4 Poli 50 Hz			6 Poles 50 Hz 6 Poles 50 Hz 6 Poli 50 Hz		
	Max. number starts/hour* Макс. кол-во пусков в час* Numero massimo di avviamenti/ora*	Voltage variation Изменение напряжения Variazione di tensione	Dynamic momentum J Динамич. момент J Momento dinamico J	Max. number starts/hour* Макс. кол-во пусков в час* Numero massimo di avviamenti/ora*	Voltage variation Изменение напряжения Variazione di tensione	Dynamic momentum J Динамич. момент J Momento dinamico J	Max. number starts/hour* Макс. кол-во пусков в час* Numero massimo di avviamenti/ora*	Voltage variation Изменение напряжения Variazione di tensione	Dynamic momentum J Динамич. момент J Momento dinamico J
	[kW]	[%]	[kg m ²]	[kW]	[%]	[kg m ²]	[kW]	[%]	[kg m ²]
0,75	3	± 10 (400V)	0,001	3	± 10 (400V)	0,003	3	± 10 (400V)	0,005
1,1	3	± 10 (400V)	0,002	3	± 10 (400V)	0,004	3	± 10 (400V)	0,008
1,5	3	± 10 (400V)	0,002	3	± 10 (400V)	0,005	3	± 10 (400V)	0,013
2,2	3	± 10 (400V)	0,003	3	± 10 (400V)	0,01	3	± 10 (400V)	0,02
3	3	± 10 (400V)	0,005	3	± 10 (400V)	0,013	3	± 10 (400V)	0,037
4	3	± 10 (400V)	0,008	3	± 10 (400V)	0,02	3	± 10 (400V)	0,05
5,5	3	± 10 (400V)	0,014	3	± 10 (400V)	0,035	3	± 10 (400V)	0,065
7,5	3	± 10 (400V)	0,017	3	± 10 (400V)	0,047	3	± 10 (400V)	0,117
11	3	± 10 (400V)	0,051	3	± 10 (400V)	0,107	3	± 10 (400V)	0,177
15	3	± 10 (400V)	0,064	3	± 10 (400V)	0,129	3	± 10 (400V)	0,316
18,5	3	± 10 (400V)	0,076	3	± 10 (400V)	0,19	3	± 10 (400V)	0,468
22	3	± 10 (400V)	0,117	3	± 10 (400V)	0,226	3	± 10 (400V)	0,548
30	3	± 10 (400V)	0,174	3	± 10 (400V)	0,361	3	± 10 (400V)	0,884
37	3	± 10 (400V)	0,205	3	± 10 (400V)	0,63	3	± 10 (400V)	1,197
45	3	± 10 (400V)	0,302	3	± 10 (400V)	0,738	3	± 10 (400V)	2,338
55	3	± 10 (400V)	0,408	3	± 10 (400V)	1,024	3	± 10 (400V)	2,797
75 ○	3	± 10 (400V)	0,677	3	± 10 (400V)	1,4723	3	± 10 (400V)	3,4169
90 ○	3	± 10 (400V)	0,8001	3	± 10 (400V)	1,6775	3	± 10 (400V)	4,1524
110 ○	3	± 10 (400V)	1,5379	3	± 10 (400V)	3,4327	3	± 10 (400V)	5,0761
132 ○	3	± 10 (400V)	1,8654	3	± 10 (400V)	3,9943	3	± 10 (400V)	6,0984
160 ○	3	± 10 (400V)	2,1504	3	± 10 (400V)	4,6494	3	± 10 (400V)	9,4364
200 ○	3	± 10 (400V)	2,3575	3	± 10 (400V)	5,0238	3	± 10 (400V)	9,5737
250	3	± 10 (400V)	3,812	3	± 10 (400V)	9,297	3	± 10 (400V)	13,933
280	3	± 10 (400V)	3,812	3	± 10 (400V)	9,297	-	-	-
315	3	± 10 (400V)	4,463	3	± 10 (400V)	10,286	-	-	-
355	3	± 10 (400V)	4,463	3	± 10 (400V)	11,275	-	-	-
375	3	± 10 (400V)	5,58	3	± 10 (400V)	11,9	-	-	-

Axial drive only, by flexible coupling.

Electric motor operating limits in compliance with IEC 34-1

* Equally distributed.

"." = Contact the sales network

- Только соосный привод с помощью упругой муфты.

- Рабочий диапазон для электродвигателей в соответствии с IEC 34-1.

* Рекомендуется равномерное распределение.

"." = Обратитесь в нашу коммерческую сеть.

Azionamento solo coassiale tramite giunto elastico.

Limiti d'utilizzo motore elettrico secondo IEC 34-1.

* Consigliati equamente ripartiti.

"." = Contattare la rete di vendita

SPECIFICATIONS

Efficiency class: IE3

ХАРАКТЕРИСТИКИ

Класс эффективности: IE3.

CARATTERISTICHE

Classe di efficienza: IE3

○ Motor in IE4 efficiency class according to EU REGULATION 2019/1781. Available in other efficiency classes for non-EU markets.

○ Двигатель класса эффективности IE4 в соответствии с РЕГЛАМЕНТОМ ЕС 2019/1781. Доступны другие классы эффективности для рынков за пределами ЕС.

○ Motore in classe di efficienza IE4 in conformità al REGOLAMENTO UE2019/1781. Disponibili in altre classi di efficienza per mercati extra UE.

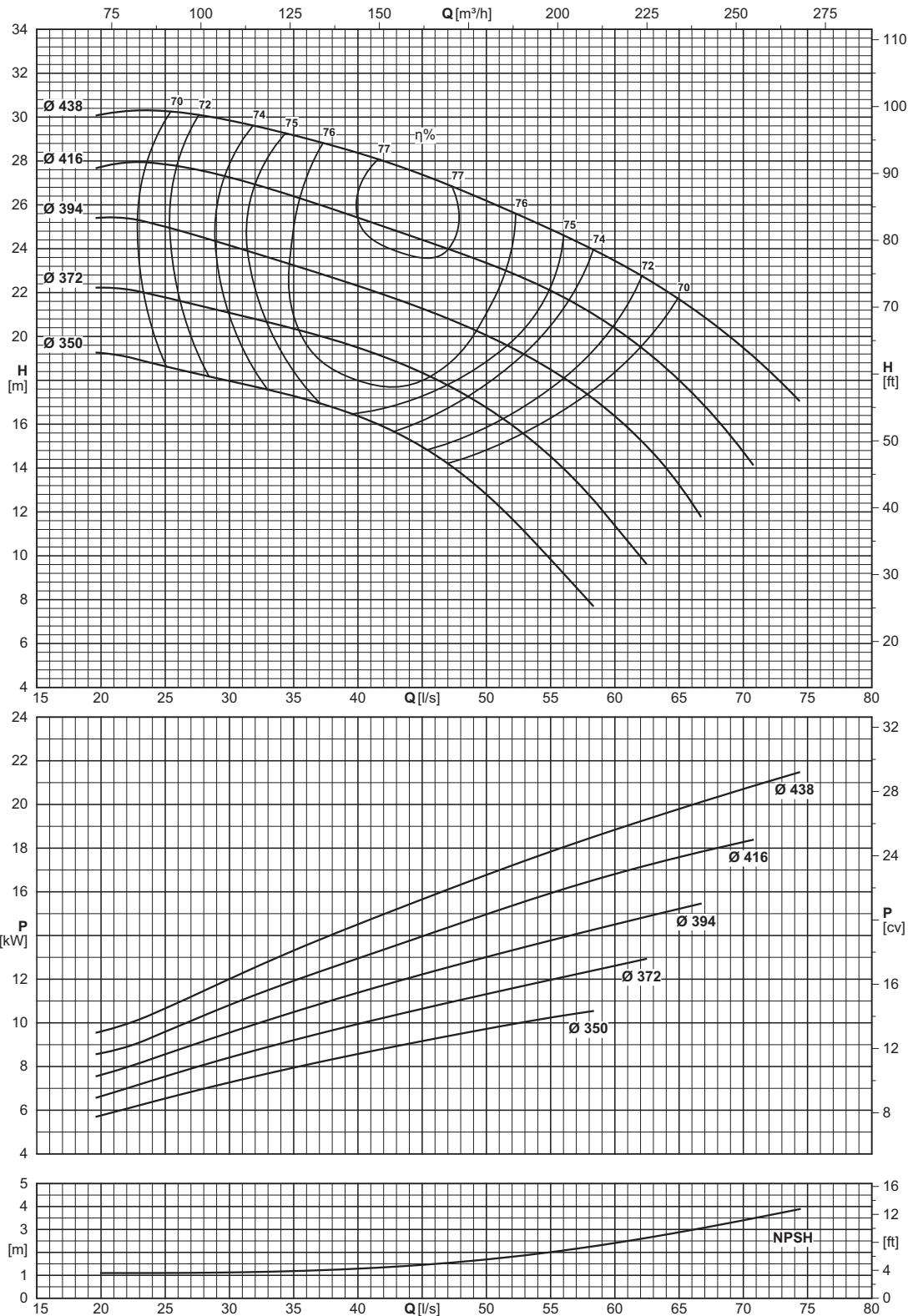

Type Тип Tipo	Inlet maximum pressure (*) Макс. давление на всасывании (*) Pressione massima in aspirazione (*)	Dynamic momentum J Динамический момент J Momento dinamico J	
		With cast iron impellers С раб. колесами из чугуна Con giranti in ghisa	With AISI 316 impellers С раб. колесами из стали AISI 316 Con giranti in AISI 316
		$J = \frac{1}{4}PD^2$	
	[bar]	[kgm ²]	
NCH125-400	6	0	(F) 0

(*) Value referred to the impeller with maximum diameter.

(*) Значение относится к раб. колесу с макс. диаметром

(*) Valore riferito alla girante con diametro massimo.

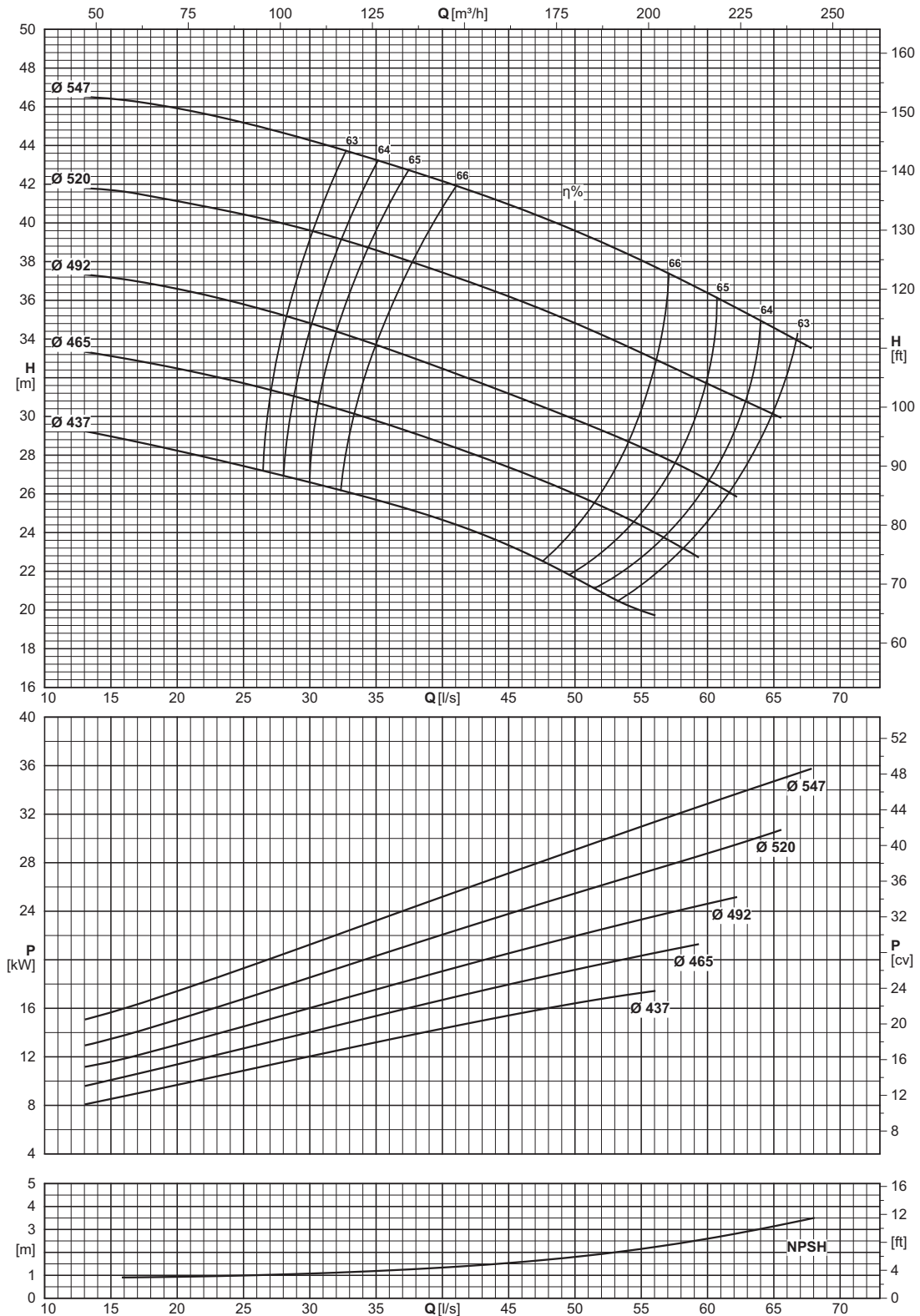

Type Тип Tipo	Inlet maximum pressure (*) Макс. давление на всасывании (*) Pressione massima in aspirazione (*)	Dynamic momentum J Динамический момент J Momento dinamico J	
		With cast iron impellers С раб. колесами из чугуна Con giranti in ghisa	With AISI 316 impellers С раб. колесами из стали AISI 316 Con giranti in AISI 316
		J=1/2 PD ²	
	[bar]	[kgm ²]	[kgm ²]
NCH125-500	4.5	0	(F) 0

(*) Value referred to the impeller with maximum diameter.

(*) Значение относится к раб. колесу с макс. диаметром.

(*) Valore riferito alla girante con diametro massimo.

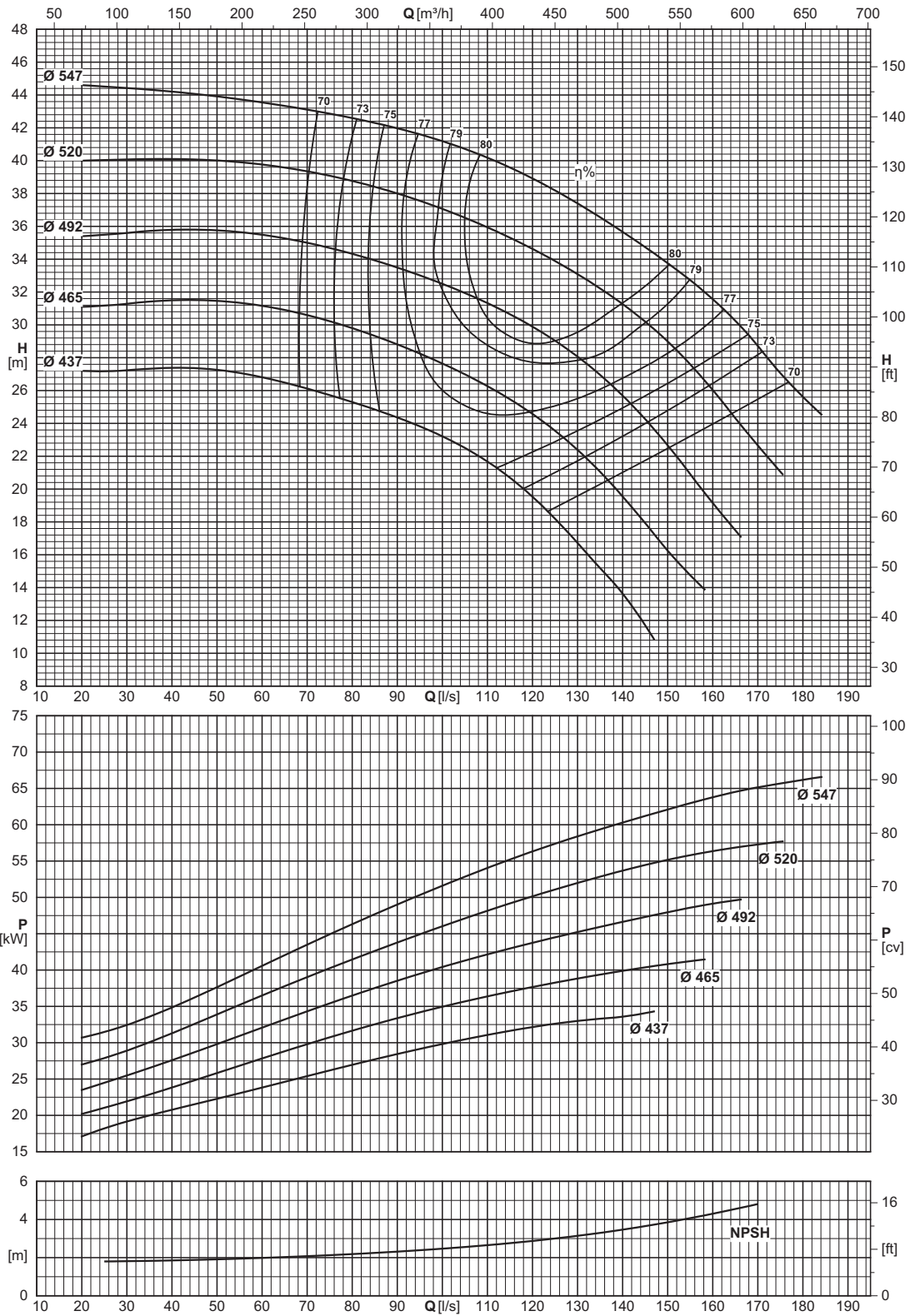

Type Тип Tipo	Inlet maximum pressure (*) Макс. давление на всасывании (*) Pressione massima in aspirazione (*)	Dynamic momentum J Динамический момент J Momento dinamico J	
		With cast iron impellers С раб. колесами из чугуна Con giranti in ghisa	With AISI 316 impellers С раб. колесами из стали AISI 316 Con giranti in AISI 316
		$J = \frac{1}{4}PD^2$	
	[bar]	[kgm ²]	
NCH200-500	4.5	0	(F) 0

(*) Value referred to the impeller with maximum diameter.

(*) Значение относится к раб. колесу с макс. диаметром.

(*) Valore riferito alla girante con diametro massimo.

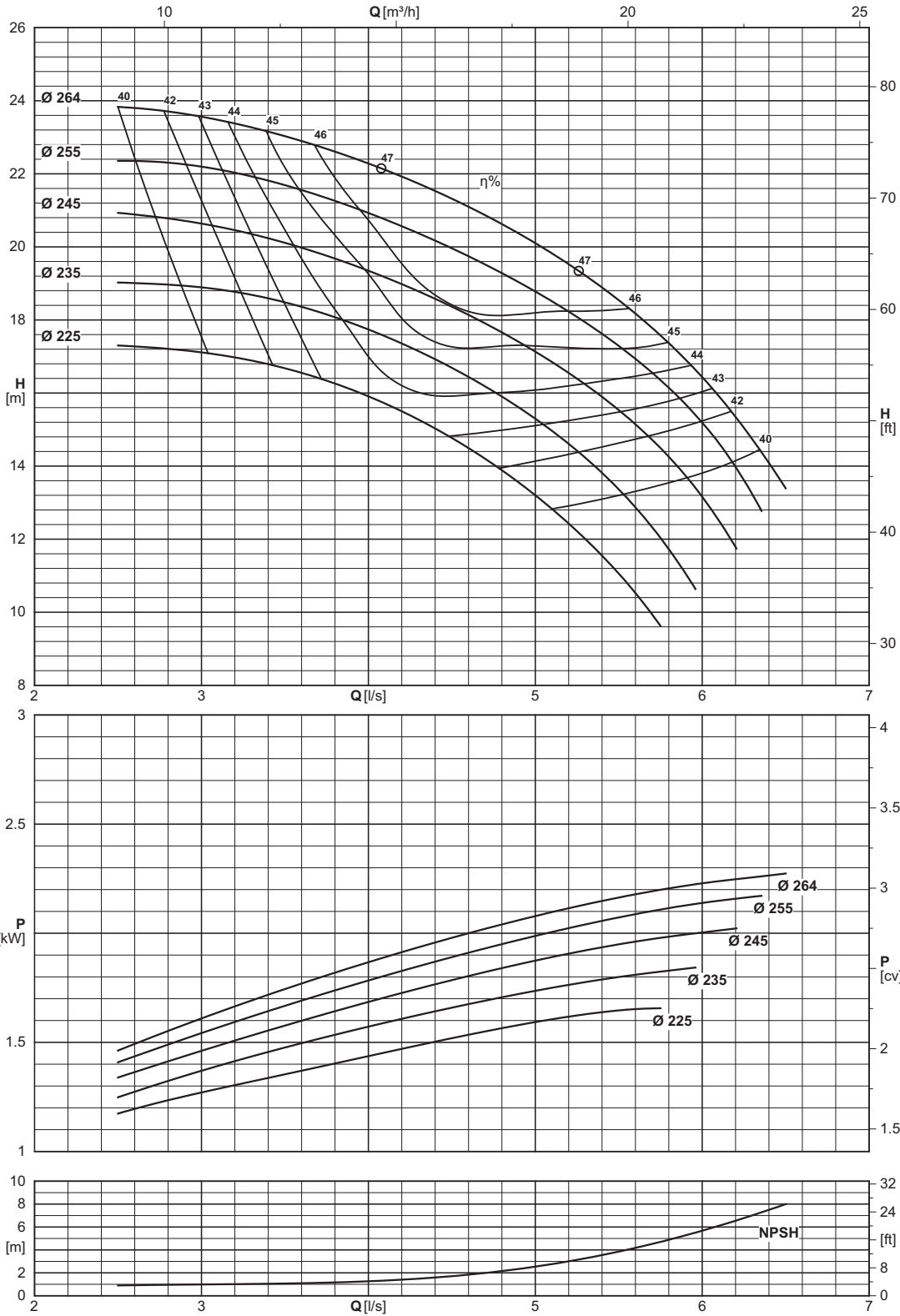

Type Тип Tipo	Inlet maximum pressure (*) Макс. давление на всасывании (*) Pressione massima in aspirazione (*)	Dynamic momentum J Динамический момент J Momento dinamico J	
		With cast iron impellers С раб. колесами из чугуна Con giranti in ghisa	With AISI 316 impellers С раб. колесами из стали AISI 316 Con giranti in AISI 316
		J = 1/4 PD ²	
	[bar]	[kgm ²]	
NC32-250	6	0,0297908	(F) 0,0340466

(*) Value referred to the impeller with maximum diameter.

(*) Значение относится к раб. колесу с макс. диаметром.

(*) Valore riferito alla girante con diametro massimo.

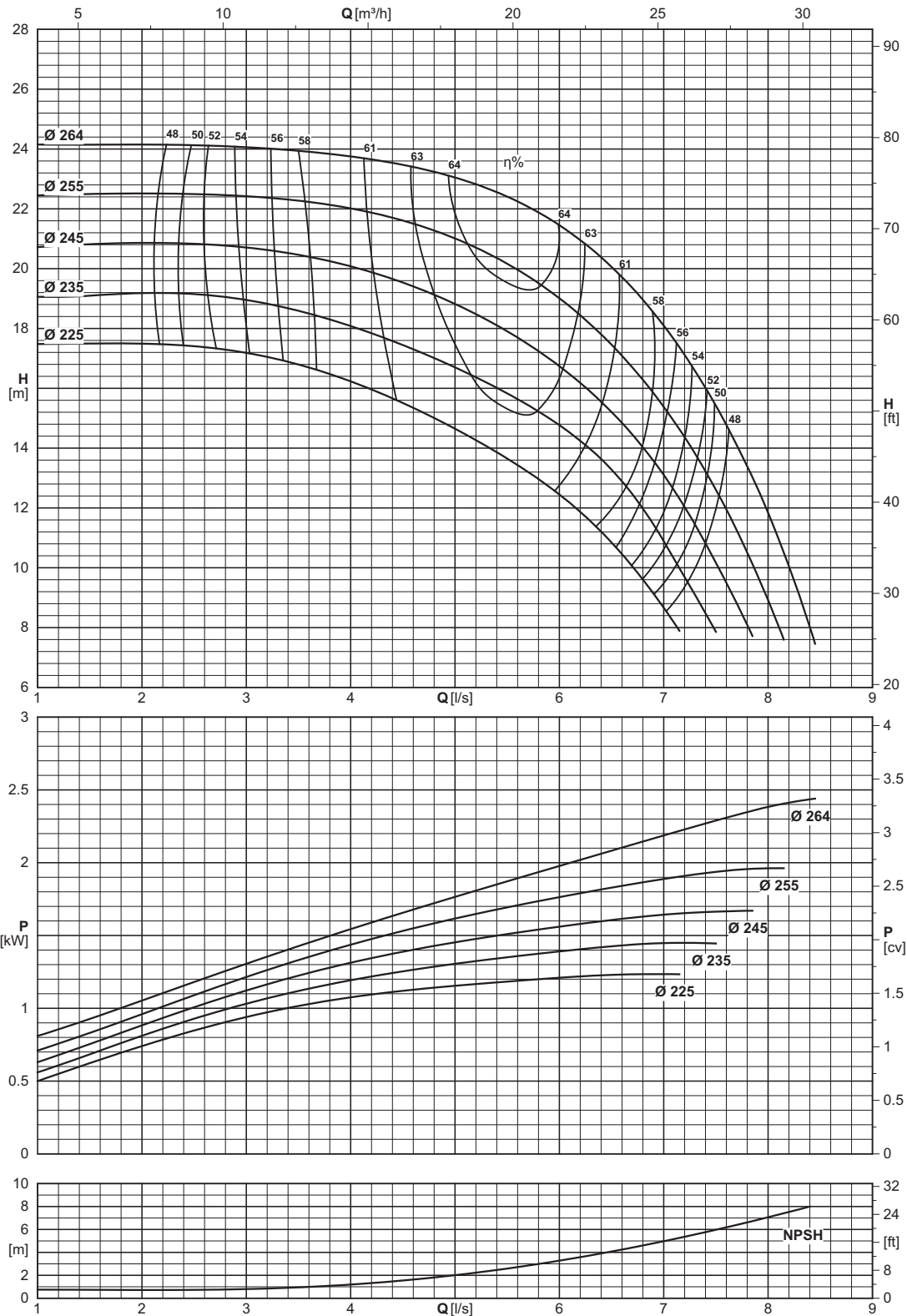

Type Тип Tipo	Inlet maximum pressure (*) Макс. давление на всасывании (*) Pressione massima in aspirazione (*)	Dynamic momentum J Динамический момент J Momento dinamico J	
		With cast iron impellers С раб. колесами из чугуна Con giranti in ghisa	With AISI 316 impellers С раб. колесами из стали AISI 316 Con giranti in AISI 316
		$J = \frac{1}{2}PD^2$	
	[bar]	[kgm ²]	
NC40-250	6	0,0411814	(F) 0,0470645

Construction reference standard EN733 (DIN24255)
(*) Value referred to the impeller with maximum diameter.

Конструкция по стандарту EN733 (DIN24255)
(*) Значение относится к раб. колесу с макс. диаметром.

Norma di riferimento costruttivo EN733 (DIN24255)
(*) Valore riferito alla girante con diametro massimo.

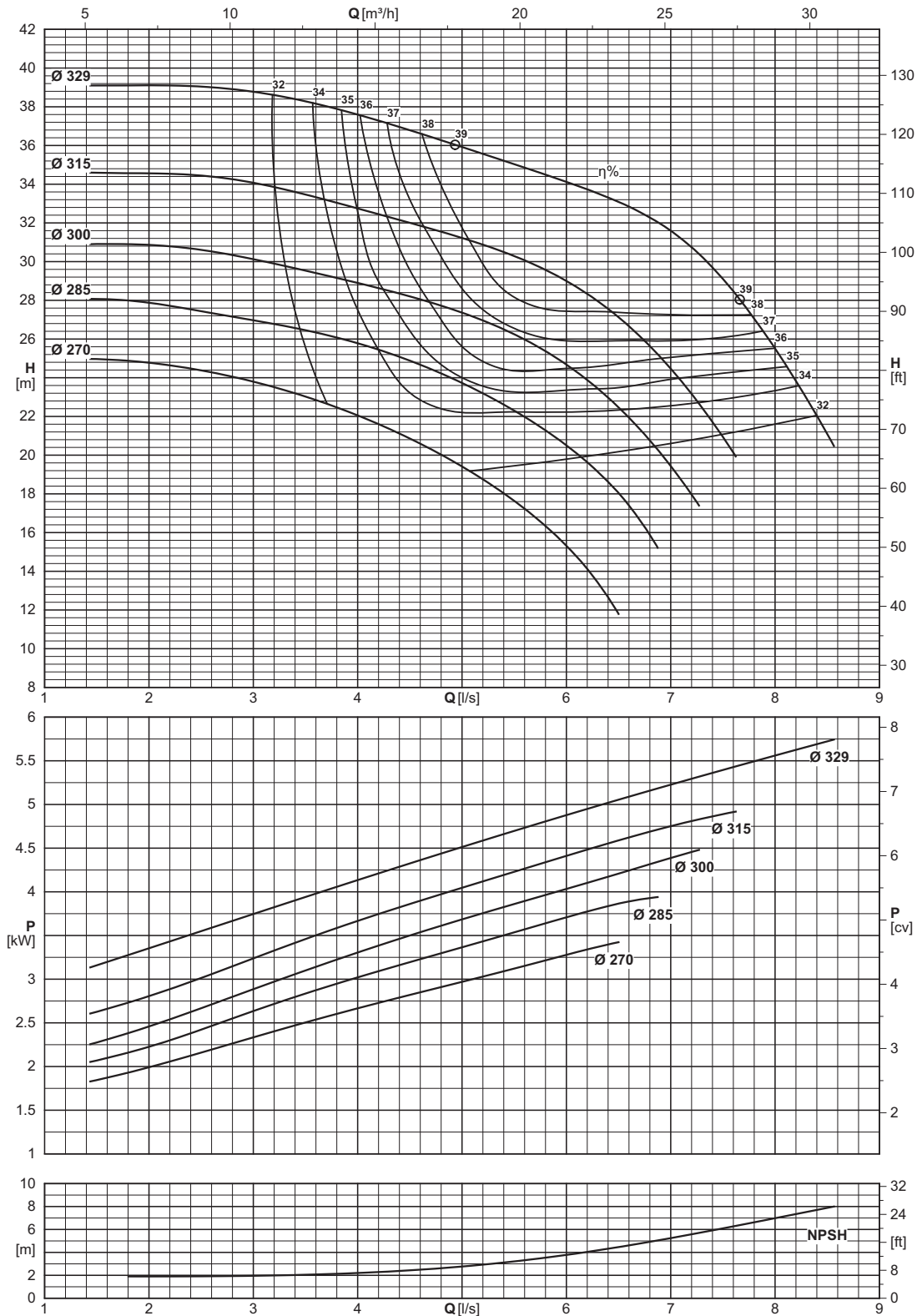

Type Тип Tipo	Inlet maximum pressure (*) Макс. давление на всасывании (*) Pressione massima in aspirazione (*)	Dynamic momentum J Динамический момент J Momento dinamico J	
		With cast iron impellers С раб. колесами из чугуна Con giranti in ghisa	With AISI 316 impellers С раб. колесами из стали AISI 316 Con giranti in AISI 316
		J=1/2 PD ²	
	[bar]	[kgm ²]	[kgm ²]
NC40-315	5	0,1049366	(F) 0,1199275

(*) Value referred to the impeller with maximum diameter.

(*) Значение относится к раб. колесу с макс. диаметром.

(*) Valore riferito alla girante con diametro massimo.

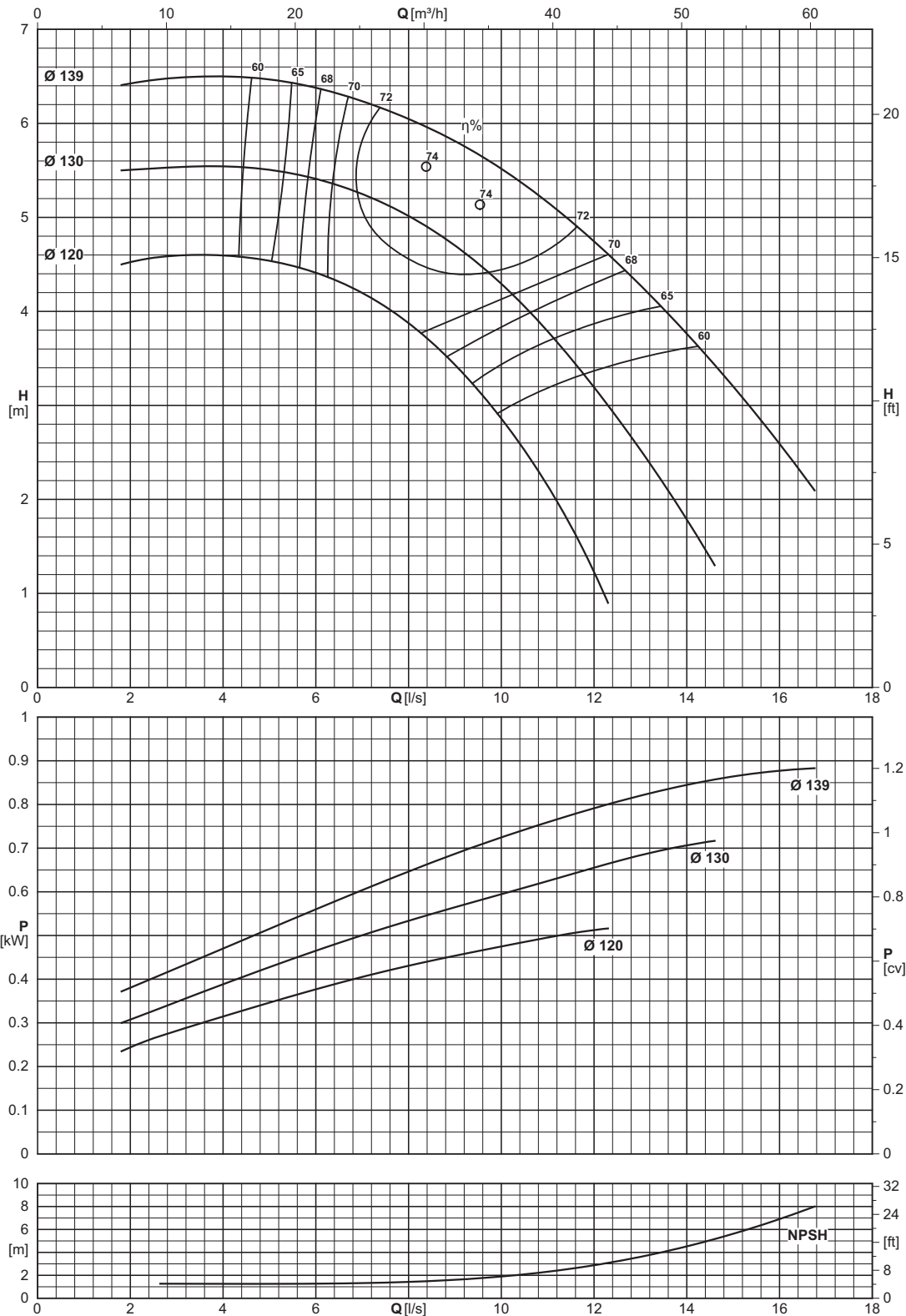

Type Тип Tipo	Inlet maximum pressure (*) Макс. давление на всасывании (*) Pressione massima in aspirazione (*)	Dynamic momentum J Динамический момент J Momento dinamico J	
		With cast iron impellers С раб. колесами из чугуна Con giranti in ghisa	With AISI 316 impellers С раб. колесами из стали AISI 316 Con giranti in AISI 316
		$J = \frac{1}{4}PD^2$	
	[bar]	[kgm ²]	
NC50-125	8	0,0036977	(F) 0,0042259

Construction reference standard EN733 (DIN24255)
(*) Value referred to the impeller with maximum diameter.

Конструкция по стандарту EN733 (DIN24255)
(*) Значение относится к раб. колесу с макс. диаметром.

Norma di riferimento costruttivo EN733 (DIN24255)
(*) Valore riferito alla girante con diametro massimo.

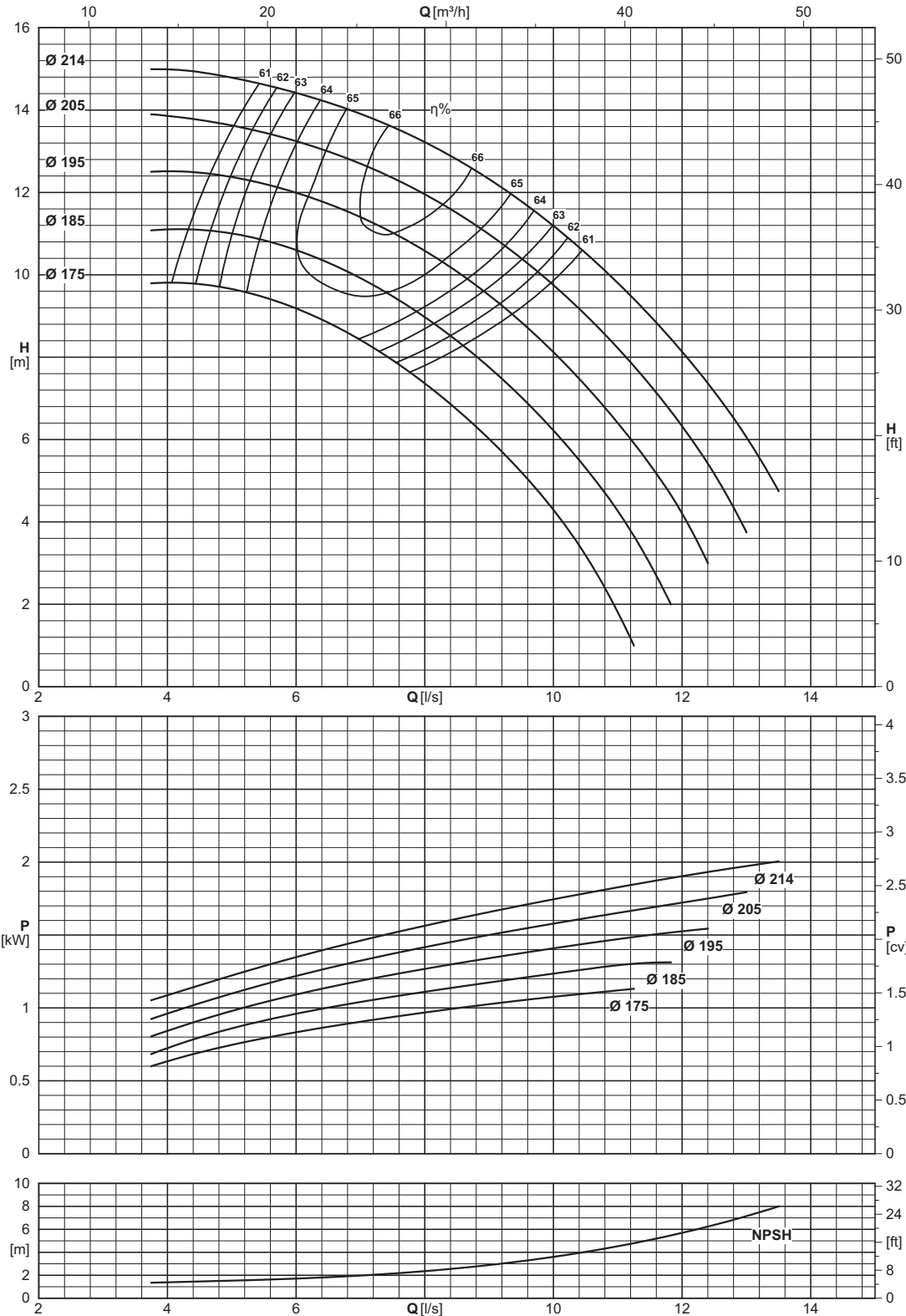

Type Тип Tipo	Inlet maximum pressure (*) Макс. давление на всасывании (*) Pressione massima in aspirazione (*)	Dynamic momentum J Динамический момент J Momento dinamico J	
		With cast iron impellers С раб. колесами из чугуна Con giranti in ghisa	With AISI 316 impellers С раб. колесами из стали AISI 316 Con giranti in AISI 316
	[bar]	J = 1/2 PD ² [kgm ²]	
NC50-200	7	0,0158799	(F) 0,0181484

Construction reference standard EN733 (DIN24255)
(*) Value referred to the impeller with maximum diameter.

Конструкция по стандарту EN733 (DIN24255)
(*) Значение относится к раб. колесу с макс. диаметром.

Norma di riferimento costruttivo EN733 (DIN24255)
(*) Valore riferito alla girante con diametro massimo.

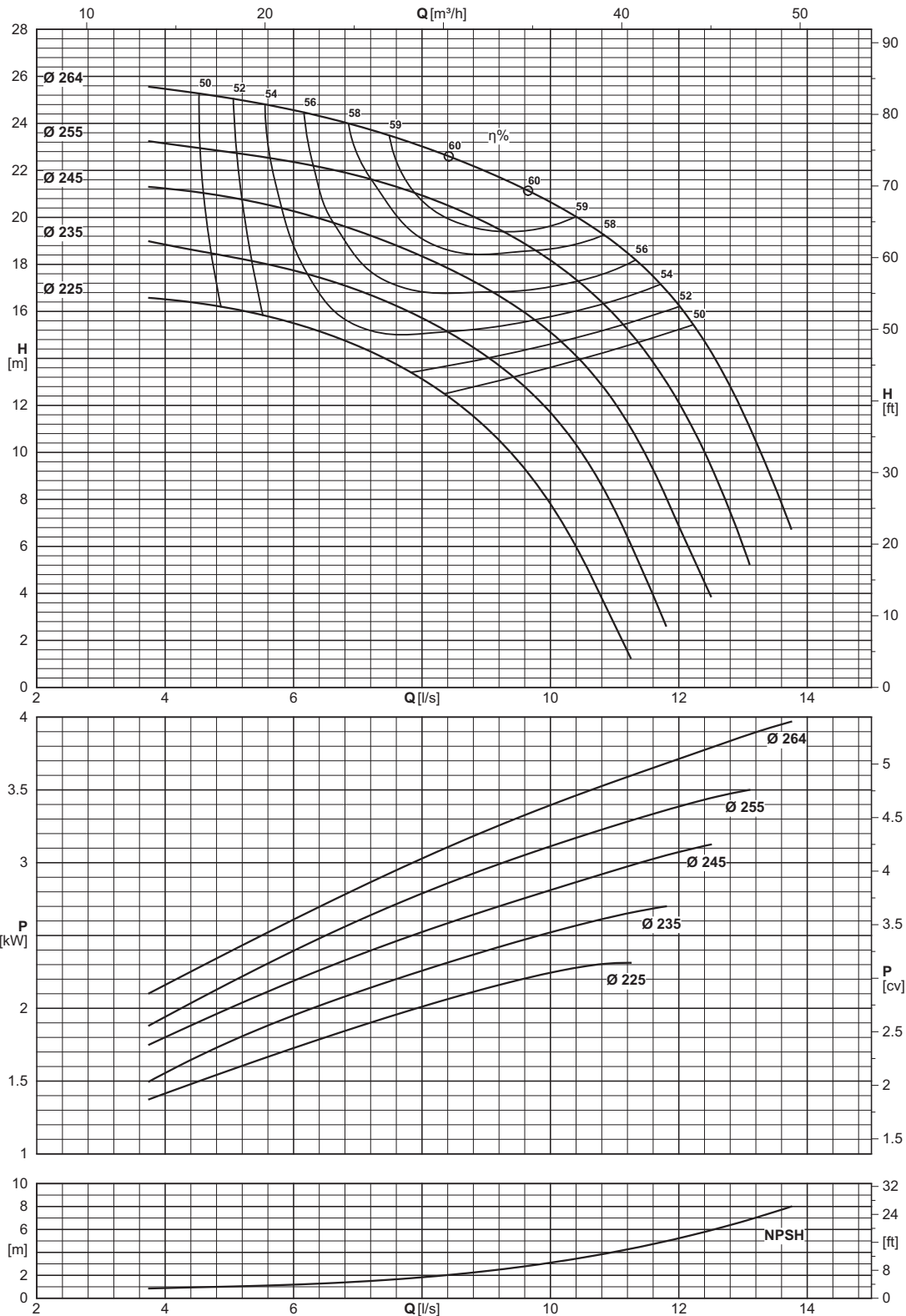

Type Тип Tipo	Inlet maximum pressure (*) Макс. давление на всасывании (*) Pressione massima in aspirazione (*)	Dynamic momentum J Динамический момент J Momento dinamico J	
		With cast iron impellers С раб. колесами из чугуна Con giranti in ghisa	With AISI 316 impellers С раб. колесами из стали AISI 316 Con giranti in AISI 316
		J=1/4PD²	
	[bar]	[kgm²]	[kgm²]
NC50-250	6	0,0385528	(F) 0,0440603

Construction reference standard EN733 (DIN24255)
(*) Value referred to the impeller with maximum diameter.

Конструкция по стандарту EN733 (DIN24255)
(*) Значение относится к раб. колесу с макс. диаметром.

Norma di riferimento costruttivo EN733 (DIN24255)
(*) Valore riferito alla girante con diametro massimo.

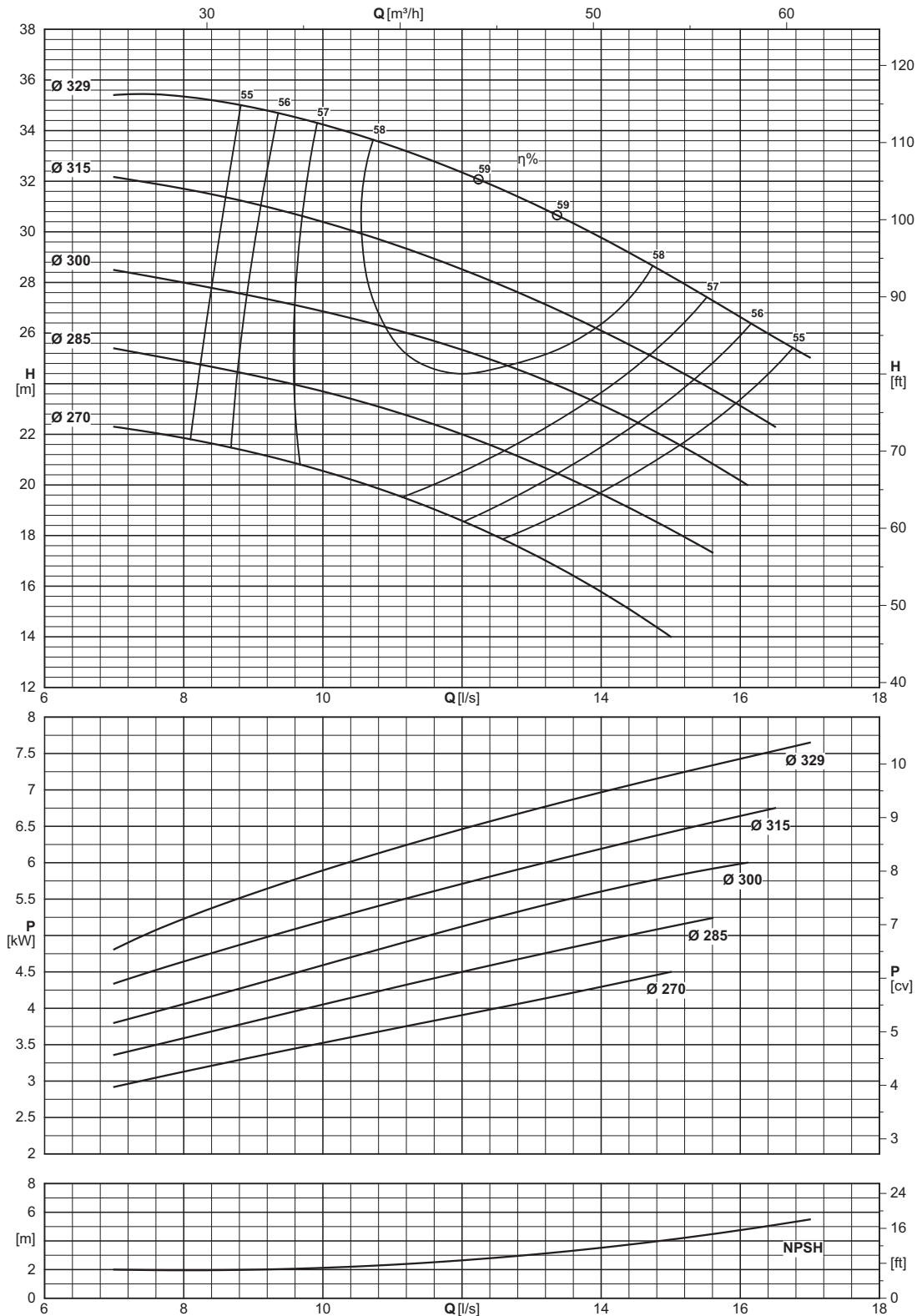

Type Тип Tipo	Inlet maximum pressure (*) Макс. давление на всасывании (*) Pressione massima in aspirazione (*)	Dynamic momentum J Динамический момент J Momento dinamico J	
		With cast iron impellers С раб. колесами из чугуна Con giranti in ghisa	With AISI 316 impellers С раб. колесами из стали AISI 316 Con giranti in AISI 316
		J=1/2 PD ²	
	[bar]	[kgm ²]	
NC50-315	5	0,101595	(F) 0,1161086

Construction reference standard EN733 (DIN24255)
(*) Value referred to the impeller with maximum diameter.

Конструкция по стандарту EN733 (DIN24255)
(*) Значение относится к раб. колесу с макс. диаметром.

Norma di riferimento costruttivo EN733 (DIN24255)
(*) Valore riferito alla girante con diametro massimo.

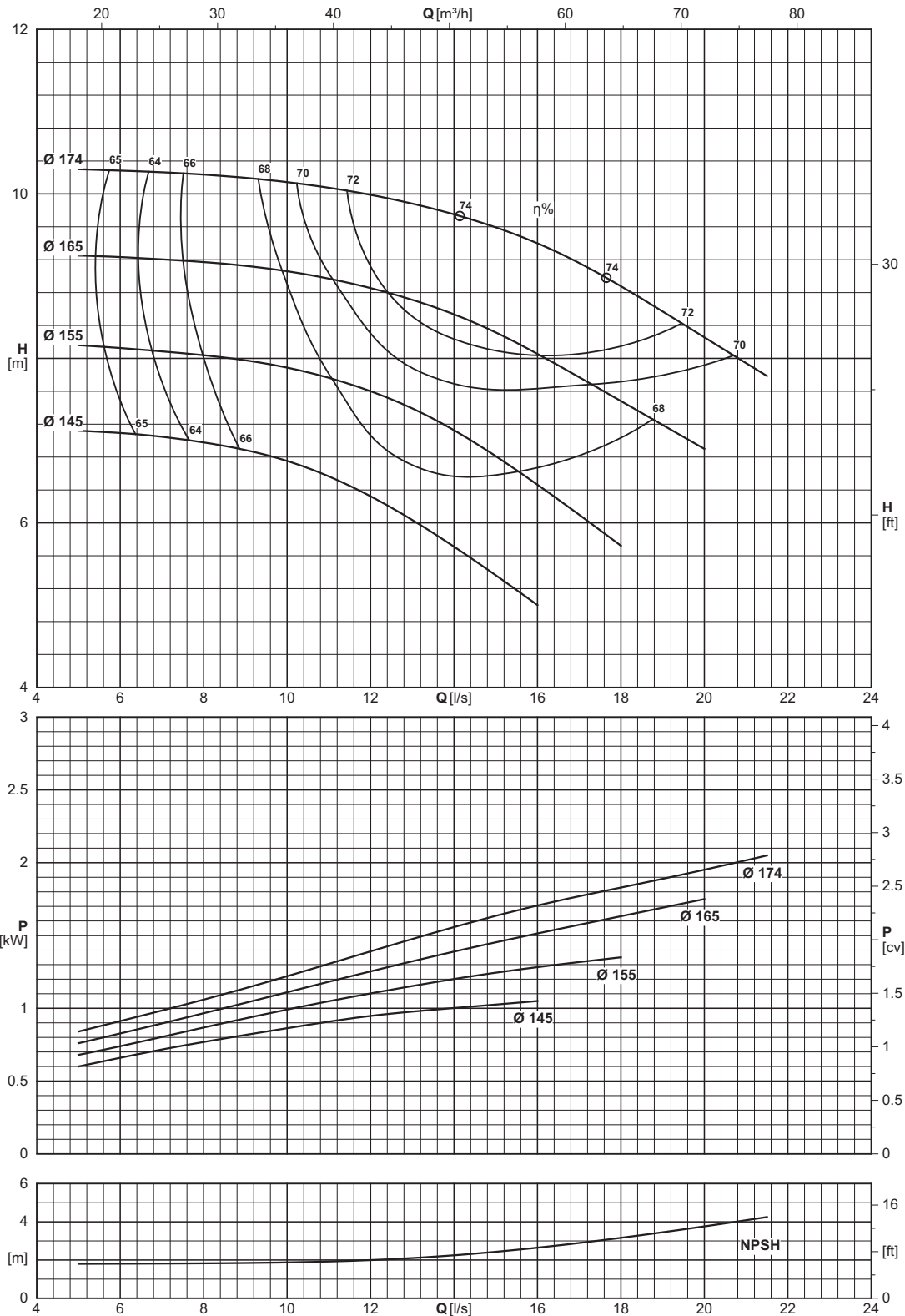

Type Тип Tipo	Inlet maximum pressure (*) Макс. давление на всасывании (*) Pressione massima in aspirazione (*)	Dynamic momentum J Динамический момент J Momento dinamico J	
		With cast iron impellers С раб. колесами из чугуна Con giranti in ghisa	With AISI 316 impellers С раб. колесами из стали AISI 316 Con giranti in AISI 316
		$J = \frac{1}{4}PD^2$	
	[bar]	[kgm ²]	
NC65-160	8	0,0078607	(F) 0,0089837

Construction reference standard EN733 (DIN24255)
(*) Value referred to the impeller with maximum diameter.

Конструкция по стандарту EN733 (DIN24255)
(*) Значение относится к раб. колесу с макс. диаметром.

Norma di riferimento costruttivo EN733 (DIN24255)
(*) Valore riferito alla girante con diametro massimo.

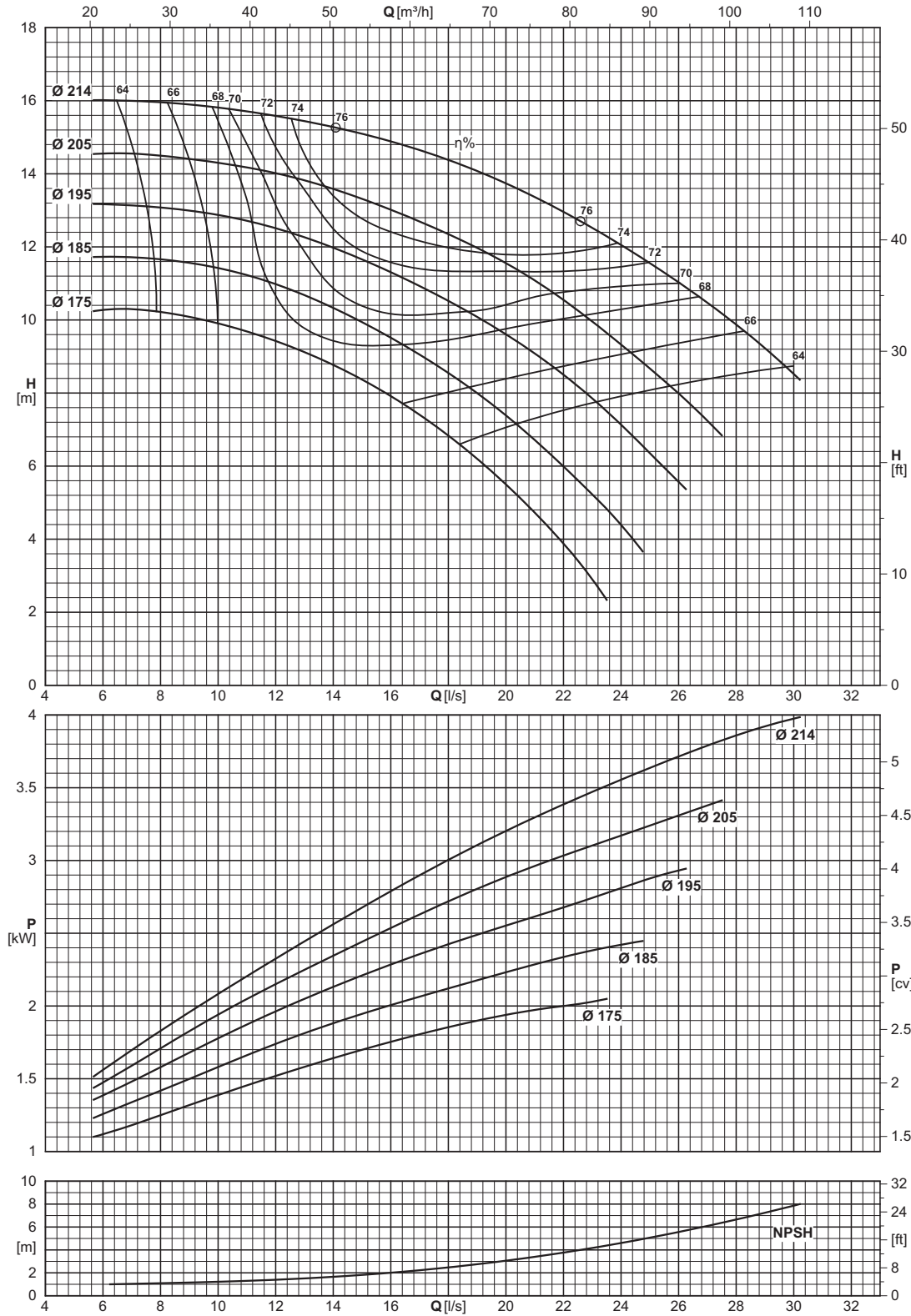

Type Тип Tipo	Inlet maximum pressure (*) Макс. давление на всасывании (*) Pressione massima in aspirazione (*)	Dynamic momentum J Динамический момент J Momento dinamico J	
		With cast iron impellers С раб. колесами из чугуна Con giranti in ghisa	With AISI 316 impellers С раб. колесами из стали AISI 316 Con giranti in AISI 316
		J = 1/4 PD ²	
	[bar]	[kgm ²]	
NC65-200	7	0,0158799	(F) 0,0181484

Construction reference standard EN733 (DIN24255)
(*) Value referred to the impeller with maximum diameter.

Конструкция по стандарту EN733 (DIN24255)
(*) Значение относится к раб. колесу с макс. диаметром.

Norma di riferimento costruttivo EN733 (DIN24255)
(*) Valore riferito alla girante con diametro massimo.

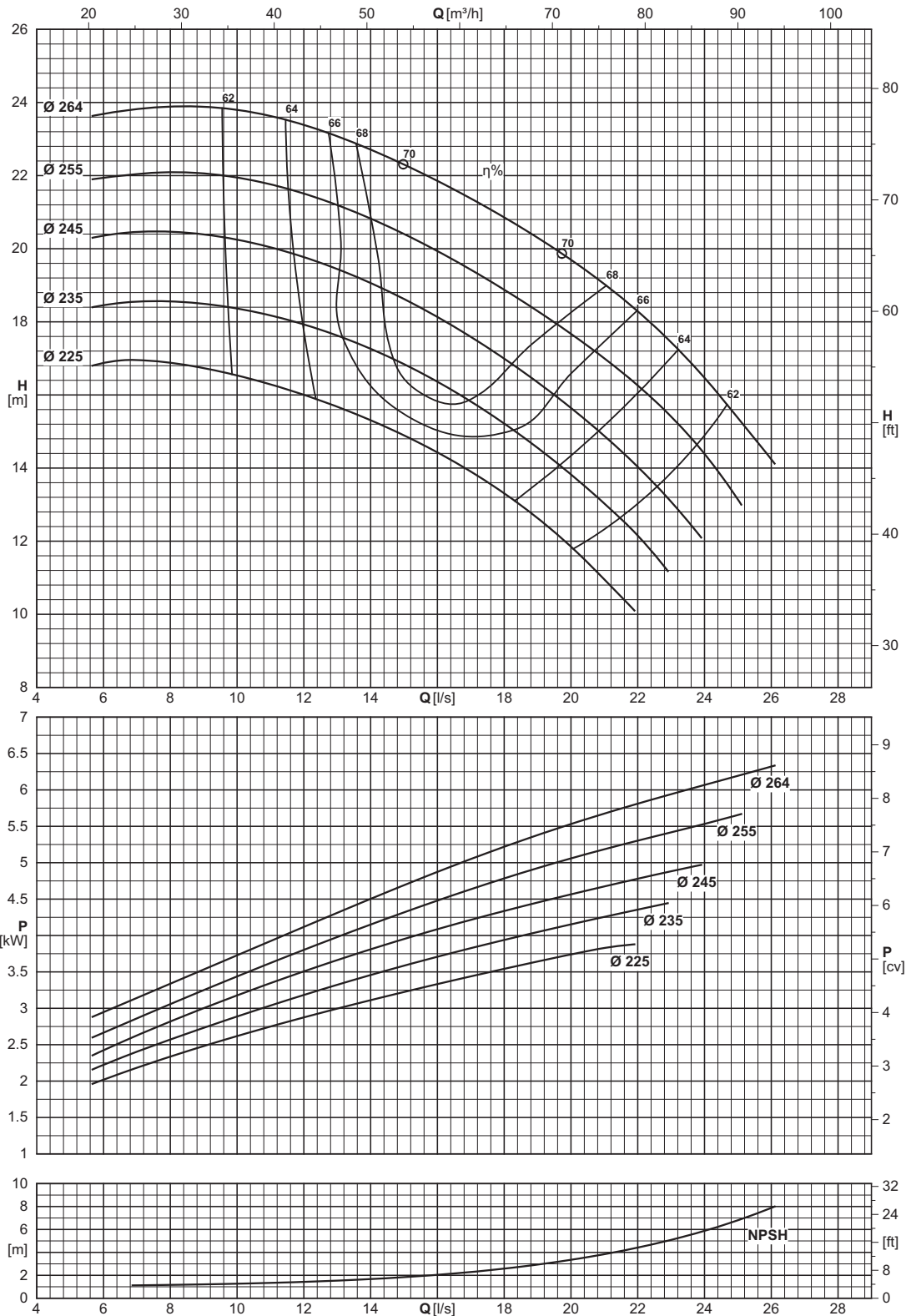

Type Тип Tipo	Inlet maximum pressure (*) Макс. давление на всасывании (*) Pressione massima in aspirazione (*)	Dynamic momentum J Динамический момент J Momento dinamico J	
		With cast iron impellers С раб. колесами из чугуна Con giranti in ghisa	With AISI 316 impellers С раб. колесами из стали AISI 316 Con giranti in AISI 316
		$J = \frac{1}{4}PD^2$	
	[bar]	[kgm ²]	
NC65-250	6	0,04405	(F) 0,0503429

Construction reference standard EN733 (DIN24255)
(*) Value referred to the impeller with maximum diameter.

Конструкция по стандарту EN733 (DIN24255)
(*) Значение относится к раб. колесу с макс. диаметром.

Norma di riferimento costruttivo EN733 (DIN24255)
(*) Valore riferito alla girante con diametro massimo.

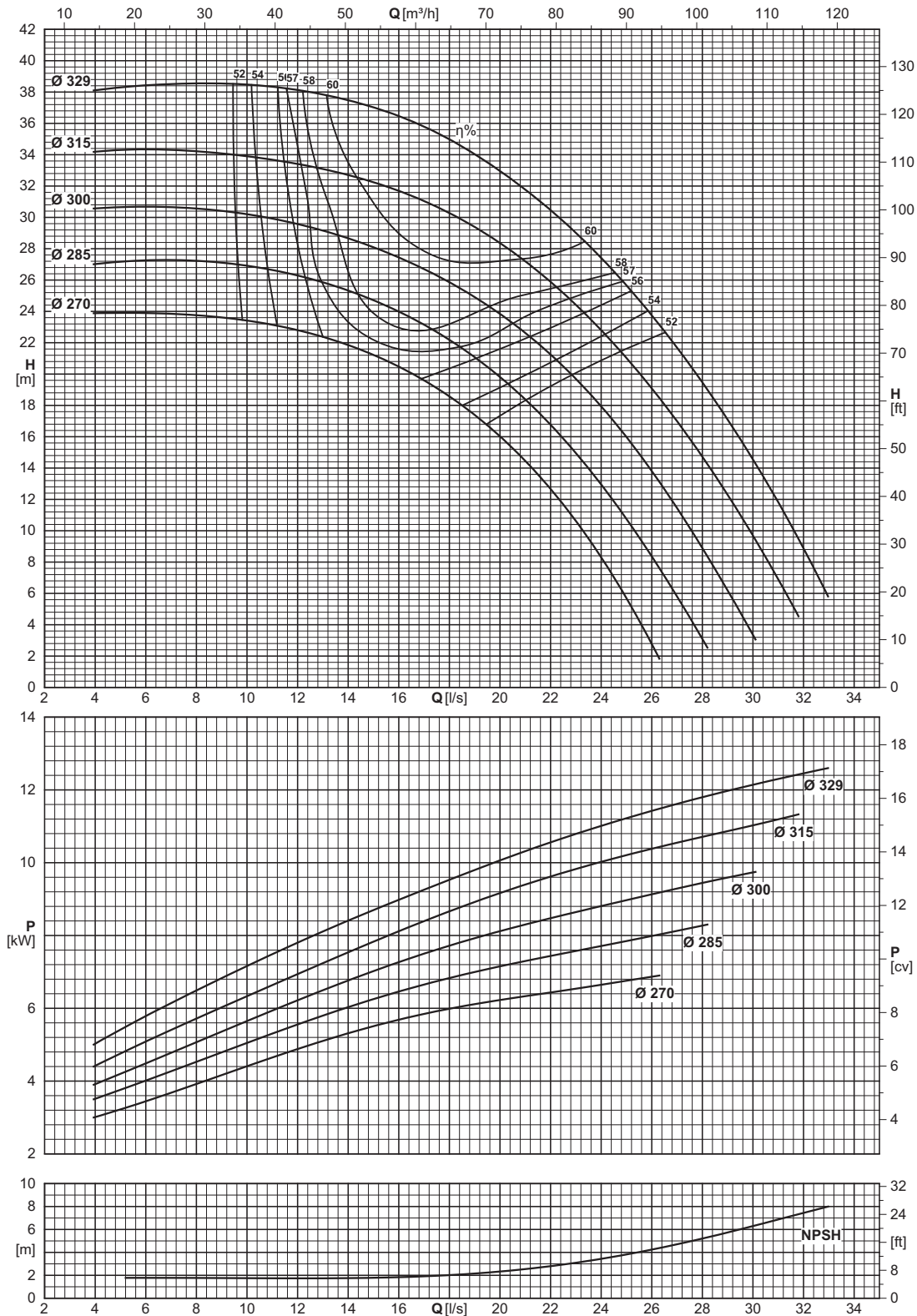

Type Тип Tipo	Inlet maximum pressure (*) Макс. давление на всасывании (*) Pressione massima in aspirazione (*)	Dynamic momentum J Динамический момент J Momento dinamico J	
		With cast iron impellers С раб. колесами из чугуна Con giranti in ghisa	With AISI 316 impellers С раб. колесами из стали AISI 316 Con giranti in AISI 316
		J = 1/4 PD ⁵	
	[bar]	[kgm ²]	
NC65-315	5	0,1117506	(F) 0,127715

Construction reference standard EN733 (DIN24255)
(*) Value referred to the impeller with maximum diameter.

Конструкция по стандарту EN733 (DIN24255)
(*) Значение относится к раб. колесу с макс. диаметром.

Norma di riferimento costruttivo EN733 (DIN24255)
(*) Valore riferito alla girante con diametro massimo.

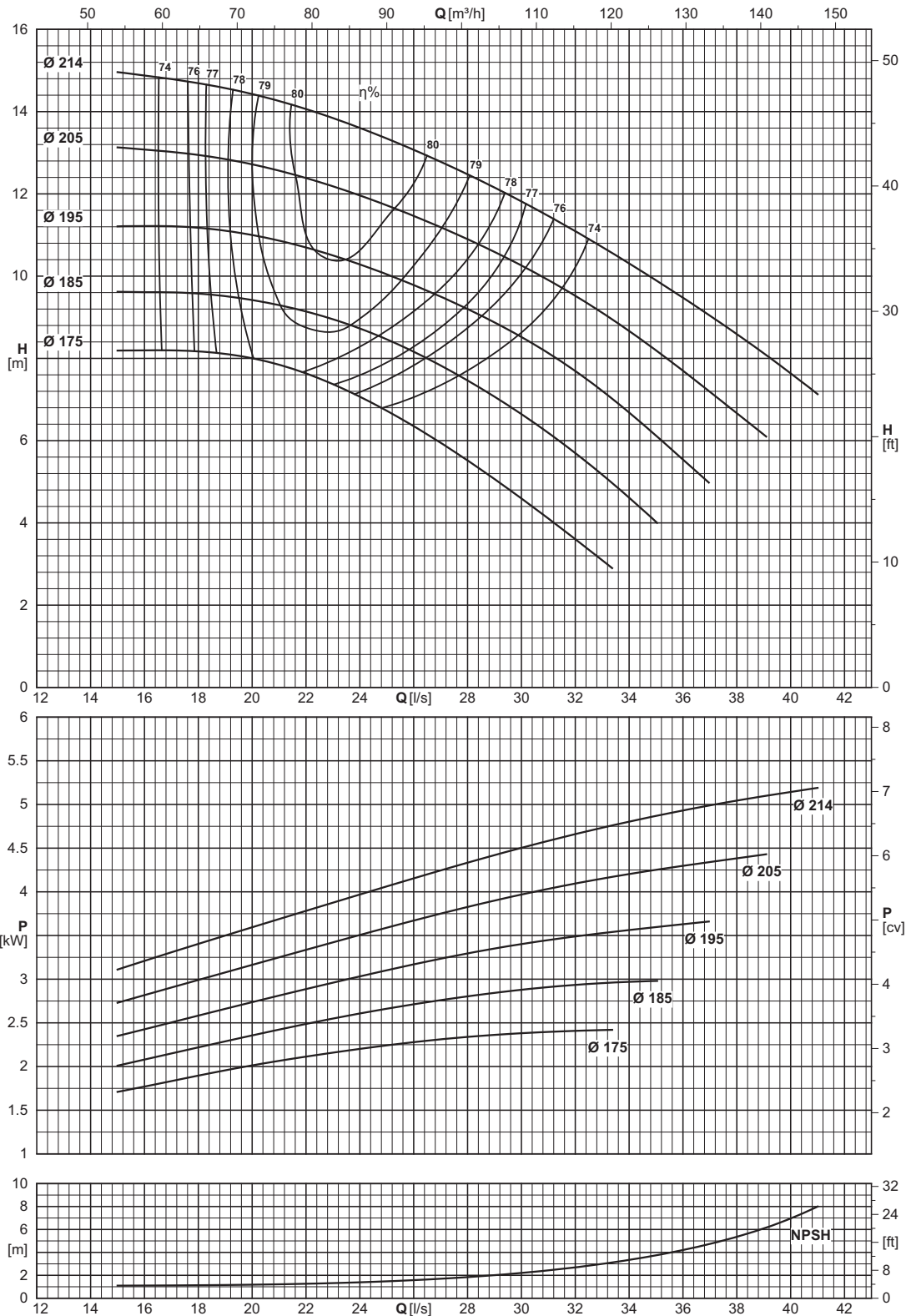

Type Тип Tipo	Inlet maximum pressure (*) Макс. давление на всасывании (*) Pressione massima in aspirazione (*)	Dynamic momentum J Динамический момент J Momento dinamico J	
		With cast iron impellers С раб. колесами из чугуна Con giranti in ghisa	With AISI 316 impellers С раб. колесами из стали AISI 316 Con giranti in AISI 316
		J=1/4PD ²	
	[bar]	[kgm ²]	[kgm ²]
NC80-200	7	0,0203788	(F) 0,02329

Construction reference standard EN733 (DIN24255)
(*) Value referred to the impeller with maximum diameter.

Конструкция по стандарту EN733 (DIN24255)
(*) Значение относится к раб. колесу с макс. диаметром.

Norma di riferimento costruttivo EN733 (DIN24255)
(*) Valore riferito alla girante con diametro massimo.

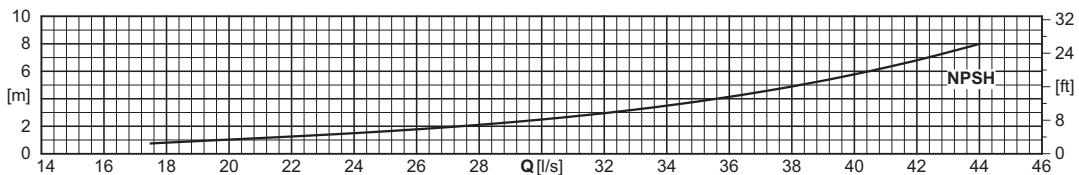
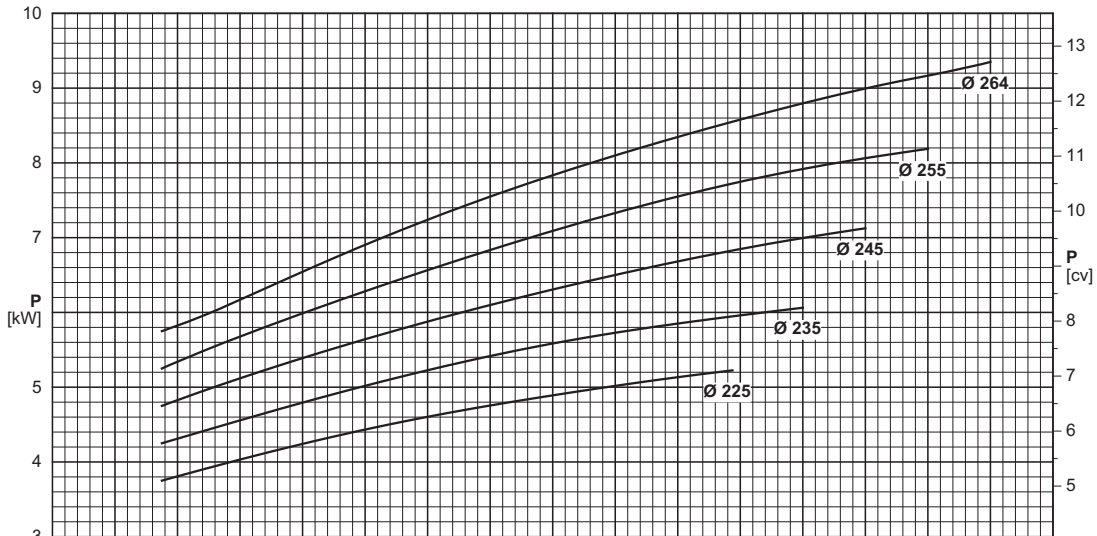
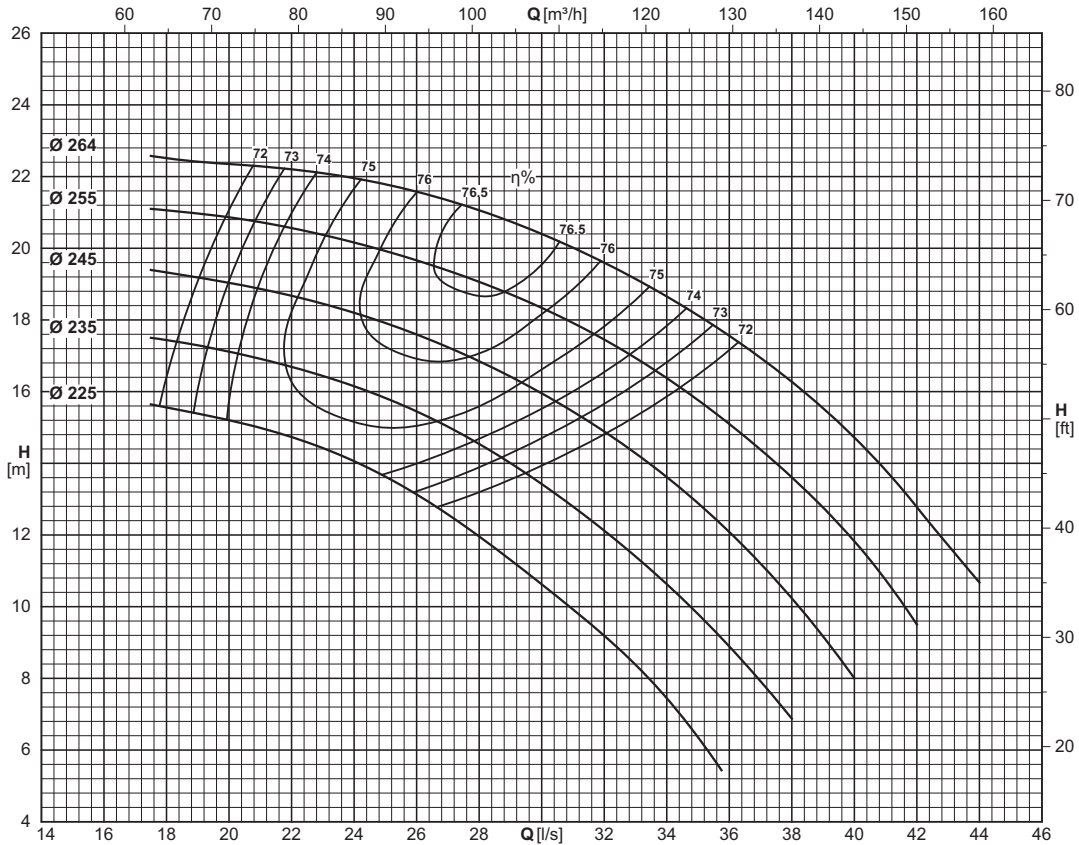

Type Тип Tipo	Inlet maximum pressure (*) Макс. давление на всасывании (*) Pressione massima in aspirazione (*)	Dynamic momentum J Динамический момент J Momento dinamico J	
		With cast iron impellers С раб. колесами из чугуна Con giranti in ghisa	With AISI 316 impellers С раб. колесами из стали AISI 316 Con giranti in AISI 316
		J = 1/4 PD ²	
	[bar]	[kgm ²]	[kgm ²]
NC80-250	6	0,0427285	(F) 0,0488326

Construction reference standard EN733 (DIN24255)
(*) Value referred to the impeller with maximum diameter.

Конструкция по стандарту EN733 (DIN24255)
(*) Значение относится к раб. колесу с макс. диаметром.

Norma di riferimento costruttivo EN733 (DIN24255)
(*) Valore riferito alla girante con diametro massimo.

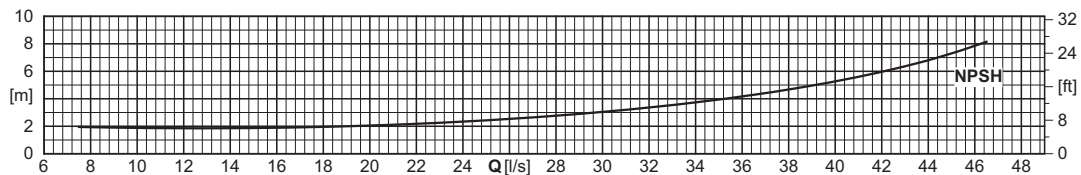
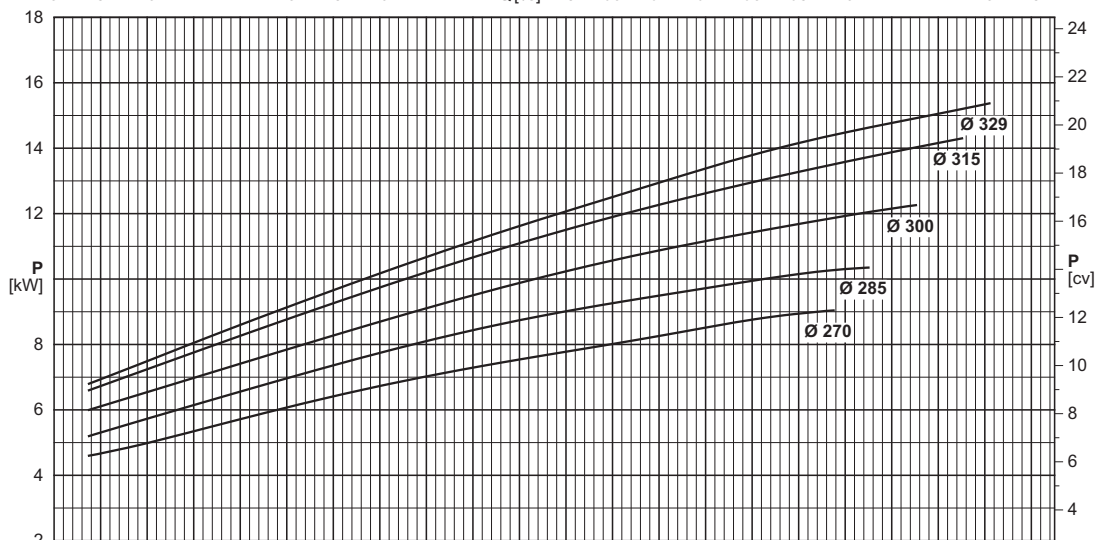
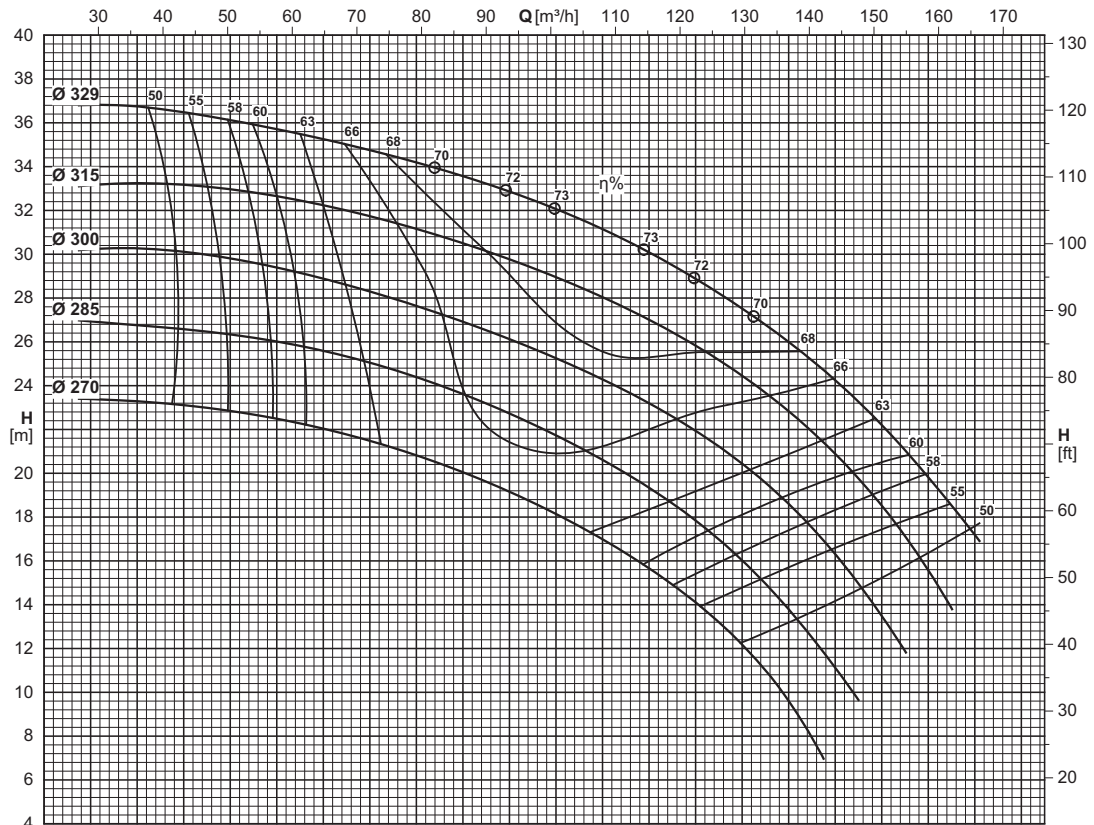

Type Тип Tipo	Inlet maximum pressure (*) Макс. давление на всасывании (*) Pressione massima in aspirazione (*)	Dynamic momentum J Динамический момент J Momento dinamico J	
		With cast iron impellers С раб. колесами из чугуна Con giranti in ghisa	With AISI 316 impellers С раб. колесами из стали AISI 316 Con giranti in AISI 316
		J=1/4PD²	
[bar]		[kgm²]	
NC80-315	5	0,109025	(F) 0,1246

Construction reference standard EN733 (DIN24255)
(*) Value referred to the impeller with maximum diameter.

Конструкция по стандарту EN733 (DIN24255)
(*) Значение относится к раб. колесу с макс. диаметром.

Norma di riferimento costruttivo EN733 (DIN24255)
(*) Valore riferito alla girante con diametro massimo.

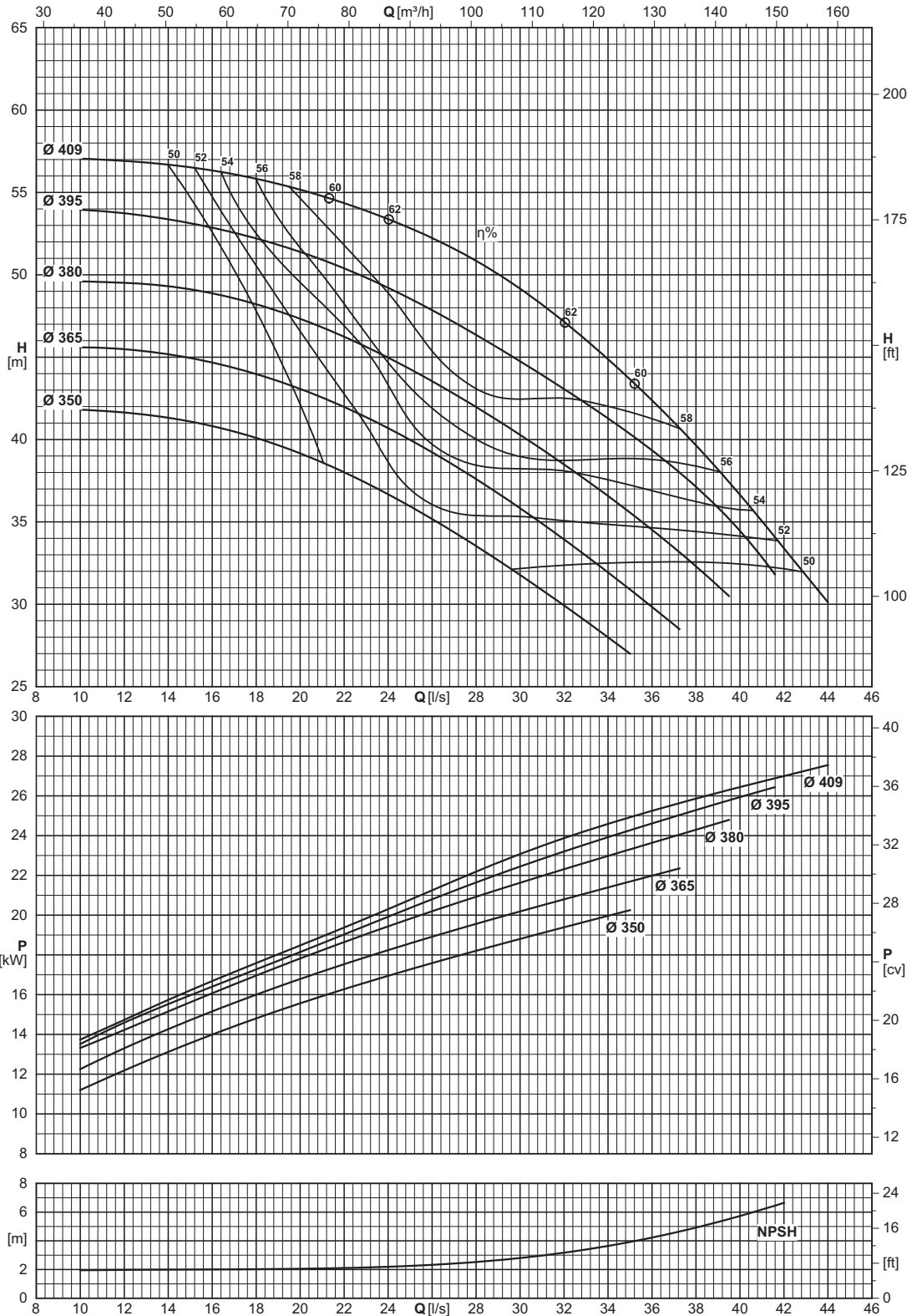

Type Тип Tipo	Inlet maximum pressure (*) Макс. давление на всасывании (*) Pressione massima in aspirazione (*)	Dynamic momentum J Динамический момент J Momento dinamico J	
		With cast iron impellers С раб. колесами из чугуна Con giranti in ghisa	With AISI 316 impellers С раб. колесами из стали AISI 316 Con giranti in AISI 316
		J=1/4PD²	
	[bar]	[kgm²]	[kgm²]
NC80-400	3	0,2214516	(F) 0,2530875

(*) Value referred to the impeller with maximum diameter.

(*) Значение относится к раб. колесу с макс. диаметром.

(*) Valore riferito alla girante con diametro massimo.

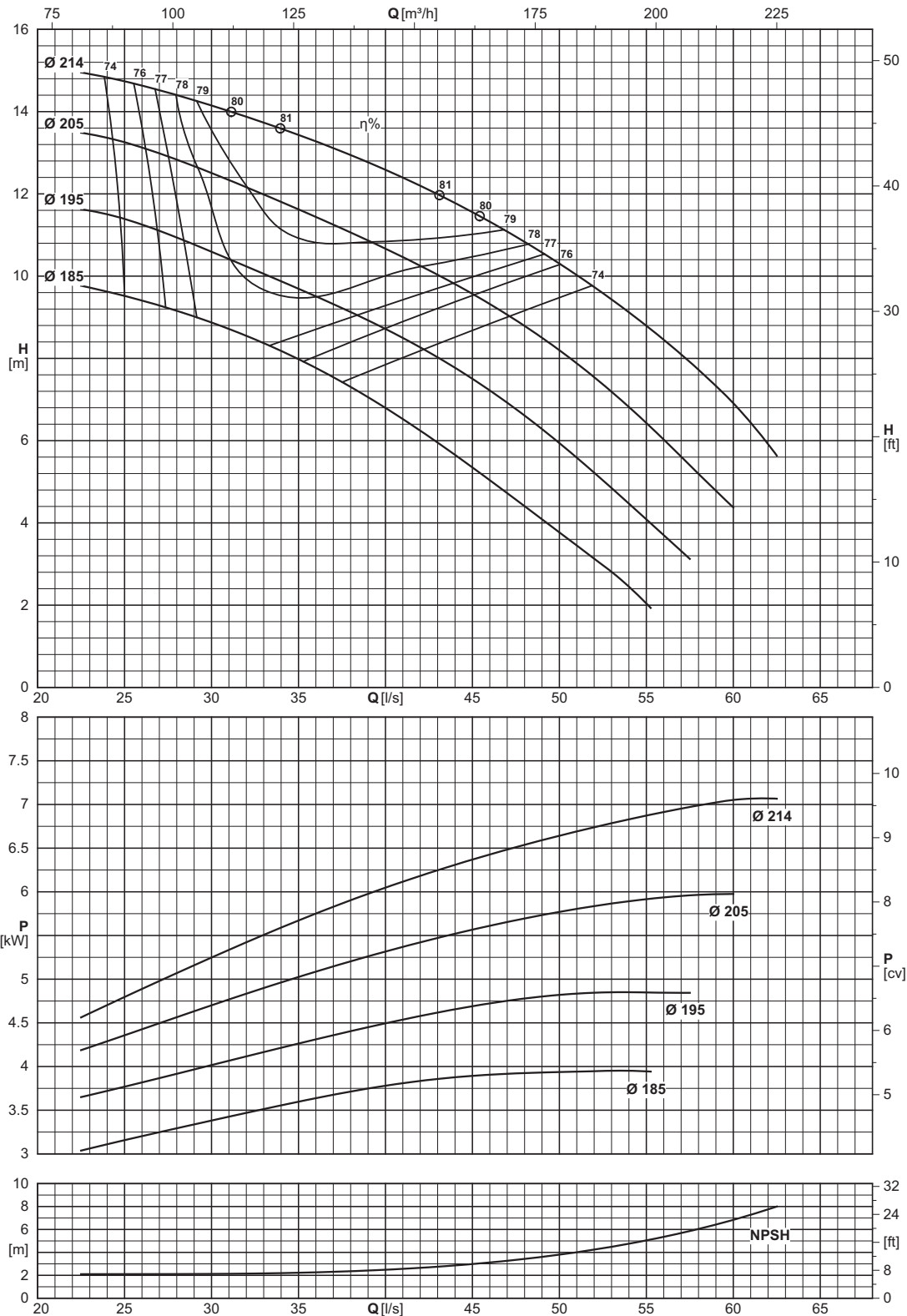

Type Тип Tipo	Inlet maximum pressure (*) Макс. давление на всасывании (*) Pressione massima in aspirazione (*)	Dynamic momentum J Динамический момент J Momento dinamico J	
		With cast iron impellers С раб. колесами из чугуна Con giranti in ghisa	With AISI 316 impellers С раб. колесами из стали AISI 316 Con giranti in AISI 316
		$J = \frac{1}{4}PD^2$	
	[bar]	[kgm ²]	
NC100-200	7	0,0247456	(F) 0,0282807

Construction reference standard EN733 (DIN24255)
(*) Value referred to the impeller with maximum diameter.

Конструкция по стандарту EN733 (DIN24255)
(*) Значение относится к раб. колесу с макс. диаметром.

Norma di riferimento costruttivo EN733 (DIN24255)
(*) Valore riferito alla girante con diametro massimo.

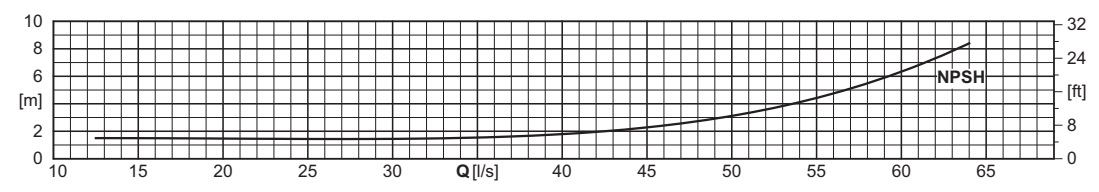
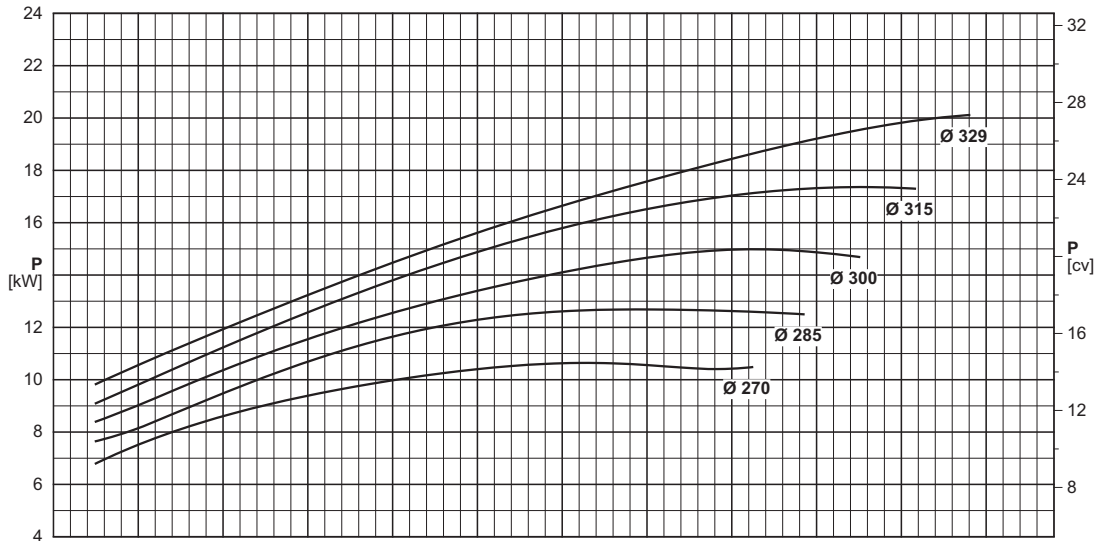
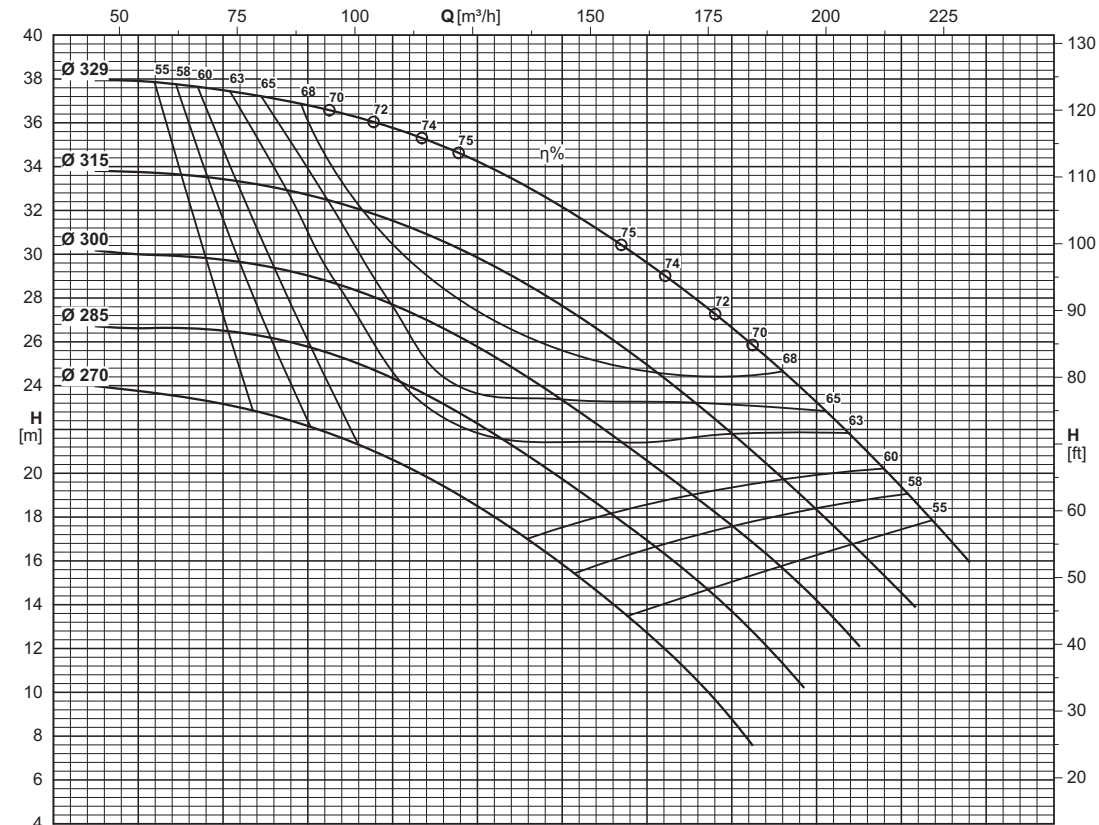

Type Тип Tipo	Inlet maximum pressure (*) Макс. давление на всасывании (*) Pressione massima in aspirazione (*)	Dynamic momentum J Динамический момент J Momento dinamico J	
		With cast iron impellers С раб. колесами из чугуна Con giranti in ghisa	With AISI 316 impellers С раб. колесами из стали AISI 316 Con giranti in AISI 316
		J = 1/2 PD ²	
[bar]		[kgm ²]	
NC100-315	5	0,1567234	(F) 0,1791125

Construction reference standard EN733 (DIN24255) Конструкция по стандарту EN733 (DIN24255) Norma di riferimento costruttivo EN733 (DIN24255)
 (*) Value referred to the impeller with maximum diameter. (*) Значение относится к раб. колесу с макс. диаметром. (*) Valore riferito alla girante con diametro massimo.

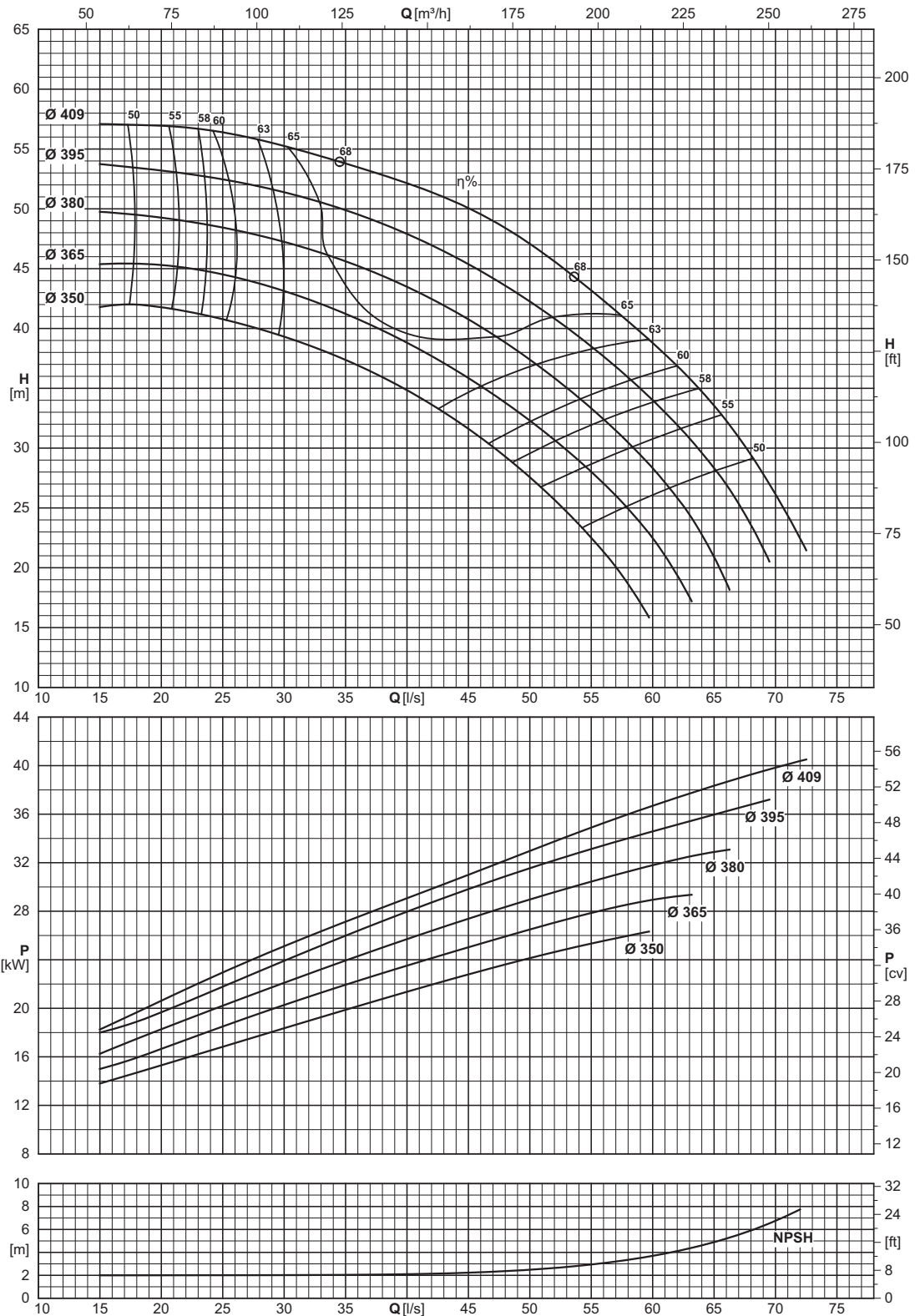

Type Тип Tipo	Inlet maximum pressure (*) Макс. давление на всасывании (*) Pressione massima in aspirazione (*)	Dynamic momentum J Динамический момент J Momento dinamico J	
		With cast iron impellers С раб. колесами из чугуна Con giranti in ghisa	With AISI 316 impellers С раб. колесами из стали AISI 316 Con giranti in AISI 316
		J=1/4PD²	
	[bar]	[kgm²]	[kgm²]
NC100-400	3	0,3058141	(F) 0,3495018

Construction reference standard EN733 (DIN24255)
(*) Value referred to the impeller with maximum diameter.

Конструкция по стандарту EN733 (DIN24255)
(*) Значение относится к раб. колесу с макс. диаметром.

Norma di riferimento costruttivo EN733 (DIN24255)
(*) Valore riferito alla girante con diametro massimo.

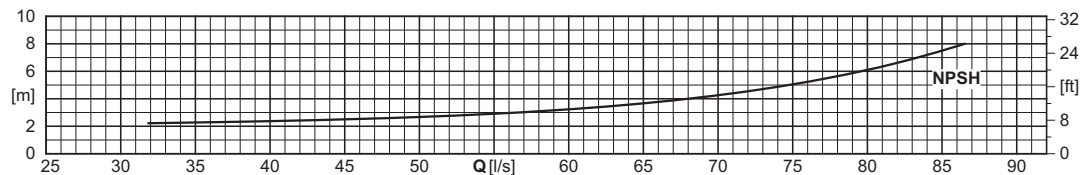
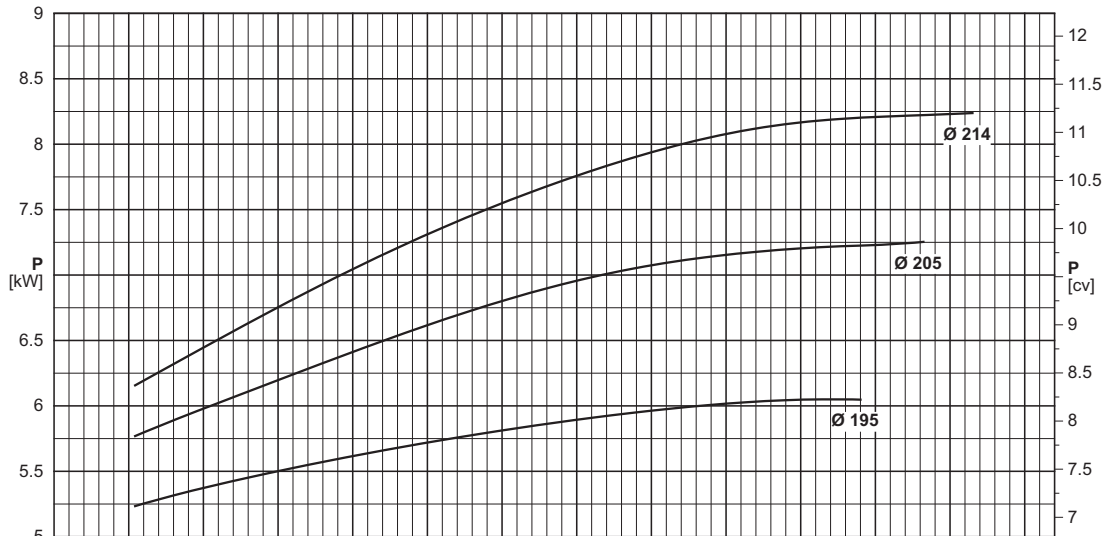
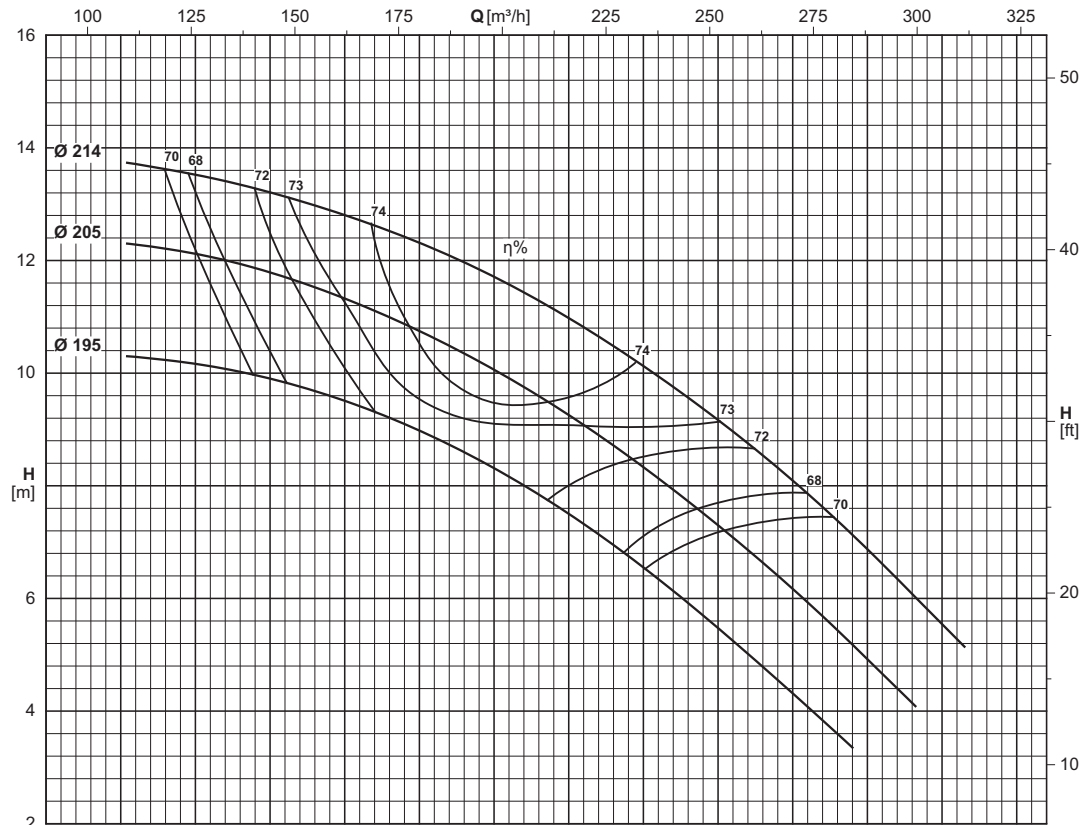

Type Тип Tipo	Inlet maximum pressure (*) Макс. давление на всасывании (*) Pressione massima in aspirazione (*)	Dynamic momentum J Динамический момент J Momento dinamico J	
		With cast iron impellers С раб. колесами из чугуна Con giranti in ghisa	With AISI 316 impellers С раб. колесами из стали AISI 316 Con giranti in AISI 316
		J = 1/4 PD ²	
[bar]		[kgm ²]	
NC125-200	7	0,0291125	(F) 0,0332714

Construction reference standard EN733 (DIN24255)
(*) Value referred to the impeller with maximum diameter.

Конструкция по стандарту EN733 (DIN24255)
(*) Значение относится к раб. колесу с макс. диаметром.

Norma di riferimento costruttivo EN733 (DIN24255)
(*) Valore riferito alla girante con diametro massimo.

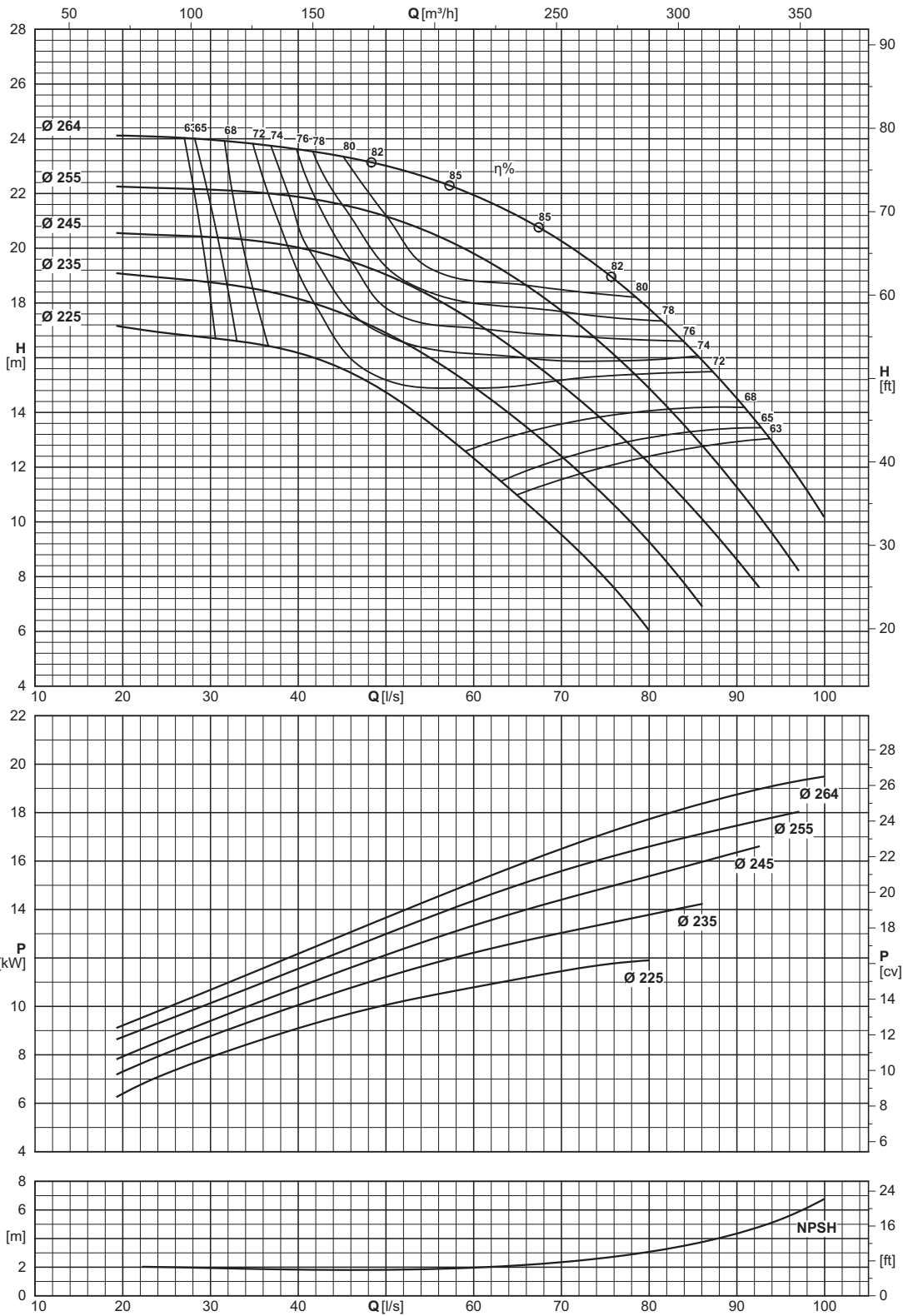

Type Тип Tipo	Inlet maximum pressure (*) Макс. давление на всасывании (*) Pressione massima in aspirazione (*)	Dynamic momentum J Динамический момент J Momento dinamico J	
		With cast iron impellers С раб. колесами из чугуна Con giranti in ghisa	With AISI 316 impellers С раб. колесами из стали AISI 316 Con giranti in AISI 316
		$J = \frac{1}{4}PD^2$	
	[bar]	[kgm ²]	
NC125-250	6	0,0660750	(F) 0,0755143

Construction reference standard EN733 (DIN24255)
(*) Value referred to the impeller with maximum diameter.

Конструкция по стандарту EN733 (DIN24255)
(*) Значение относится к раб. колесу с макс. диаметром.

Norma di riferimento costruttivo EN733 (DIN24255)
(*) Valore riferito alla girante con diametro massimo.

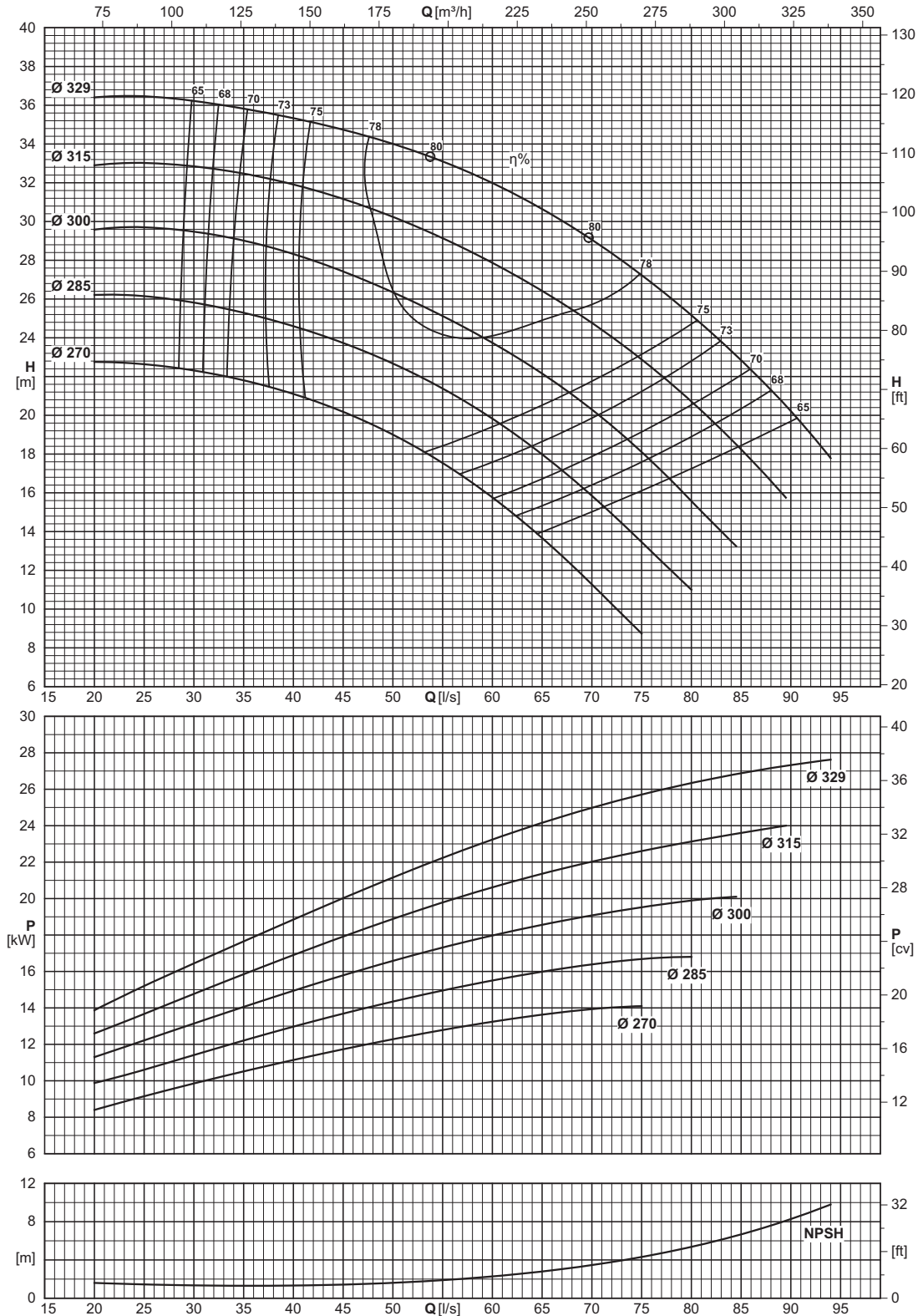

Type Тип Tipo	Inlet maximum pressure (*) Макс. давление на всасывании (*) Pressione massima in aspirazione (*)	Dinamic momentum J Динамический момент J Momento dinamico J	
		With cast iron impellers С раб. колесами из чугуна Con giranti in ghisa	With AISI 316 impellers С раб. колесами из стали AISI 316 Con giranti in AISI 316
		J = 1/2 PD ²	
	[bar]	[kgm ²]	
NC125-315	5	0,1782381	(F) 0,2037007

Construction reference standard EN733 (DIN24255)
(*) Value referred to the impeller with maximum diameter.

Конструкция по стандарту EN733 (DIN24255)
(*) Значение относится к раб. колесу с макс. диаметром.

Norma di riferimento costruttivo EN733 (DIN24255)
(*) Valore riferito alla girante con diametro massimo.

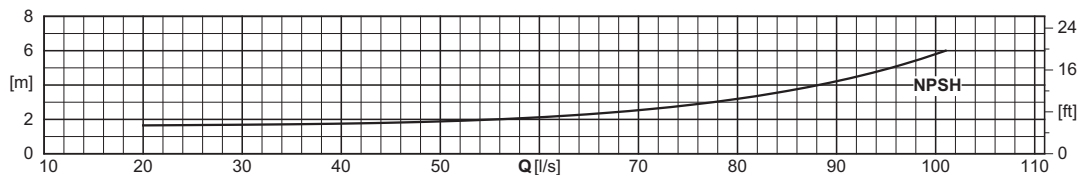
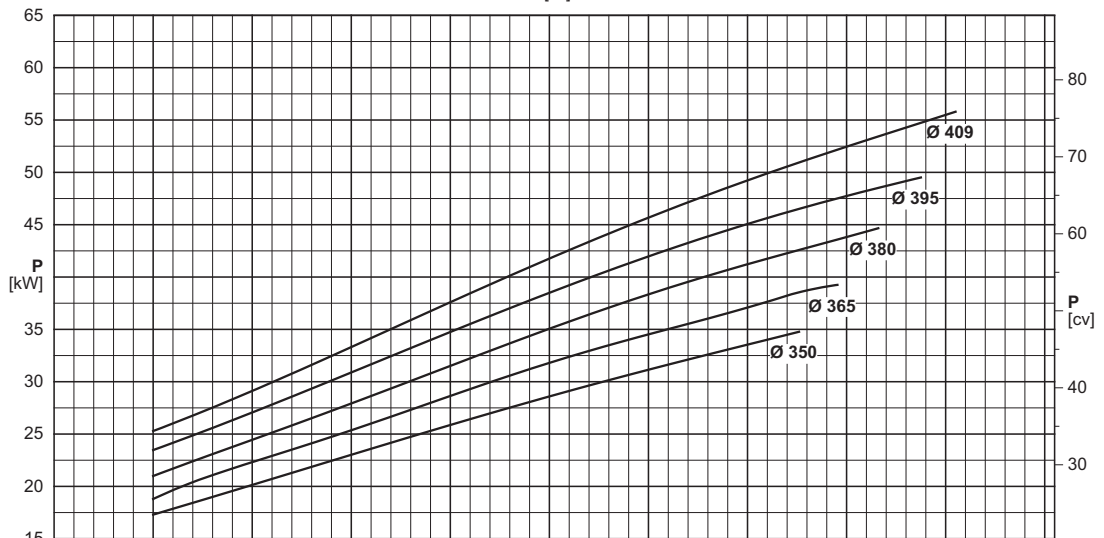
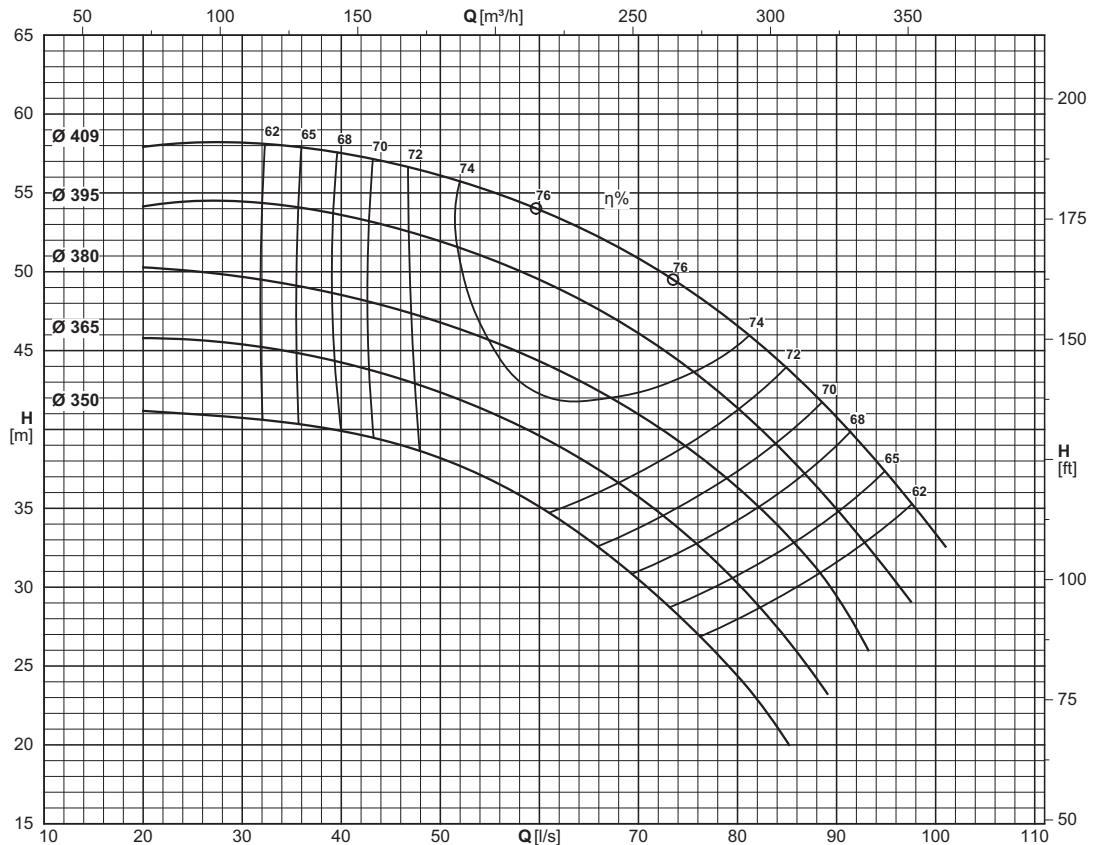

Type Тип Tipo	Inlet maximum pressure (*) Макс. давление на всасывании (*) Pressione massima in aspirazione (*)	Dynamic momentum J Динамический момент J Momento dinamico J	
		With cast iron impellers С раб. колесами из чугуна Con giranti in ghisa	With AISI 316 impellers С раб. колесами из стали AISI 316 Con giranti in AISI 316
		J=1/4PD²	
	[bar]	[kgm²]	[kgm²]
NC125-400	3	0,2636328	(F) 0,3012946

Construction reference standard EN733 (DIN24255)
(*) Value referred to the impeller with maximum diameter.

Конструкция по стандарту EN733 (DIN24255)
(*) Значение относится к раб. колесу с макс. диаметром.

Norma di riferimento costruttivo EN733 (DIN24255)
(*) Valore riferito alla girante con diametro massimo.

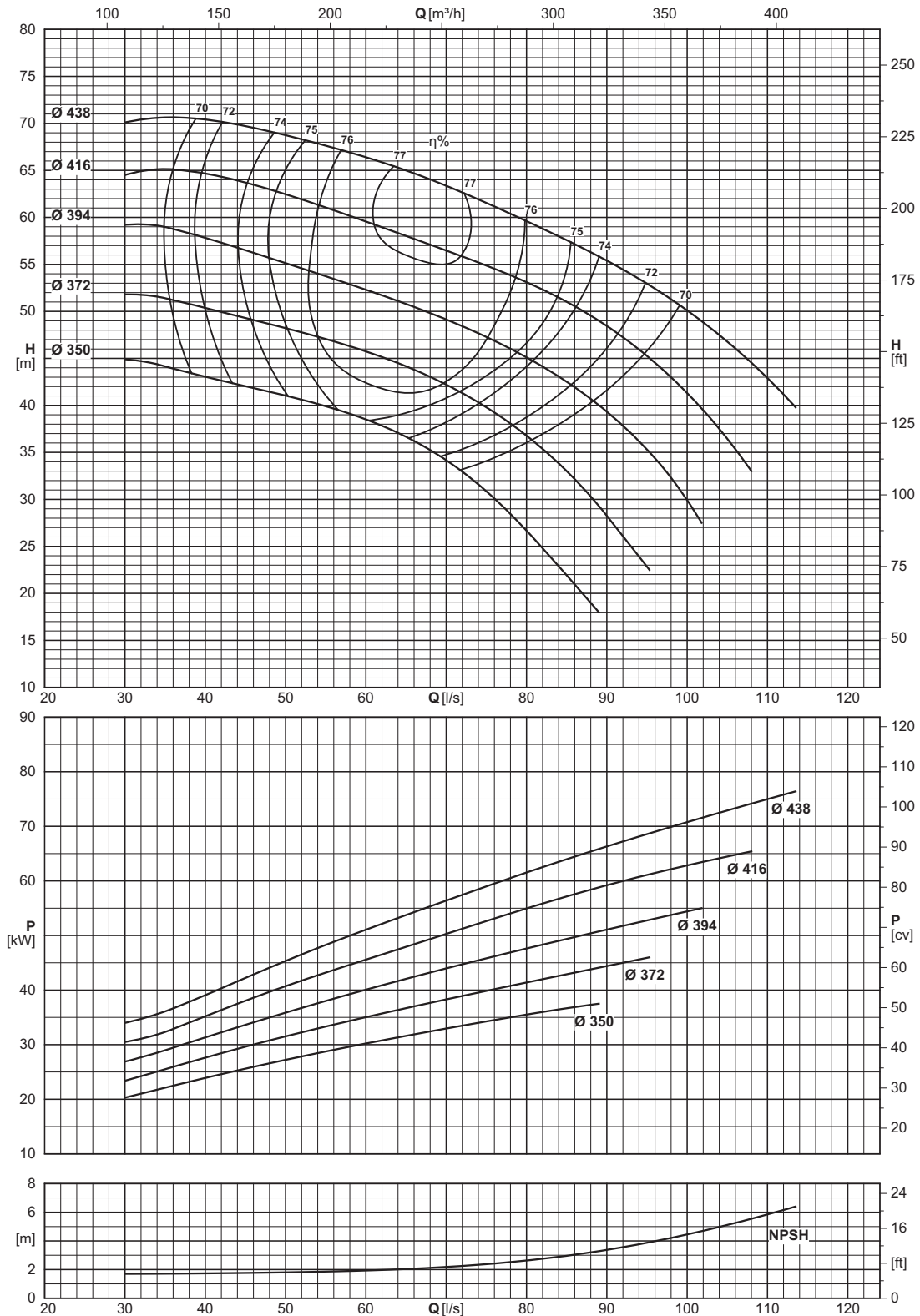

Type Тип Tipo	Inlet maximum pressure (*) Макс. давление на всасывании (*) Pressione massima in aspirazione (*)	Dynamic momentum J Динамический момент J Momento dinamico J	
		With cast iron impellers С раб. колесами из чугуна Con giranti in ghisa	With AISI 316 impellers С раб. колесами из стали AISI 316 Con giranti in AISI 316
		J = 1/4 PD ²	
	[bar]	[kgm ²]	[kgm ²]
NCH125-400	2.5	0	(F) 0

(*) Value referred to the impeller with maximum diameter.

(*) Значение относится к раб. колесу с макс. диаметром.

(*) Valore riferito alla girante con diametro massimo.

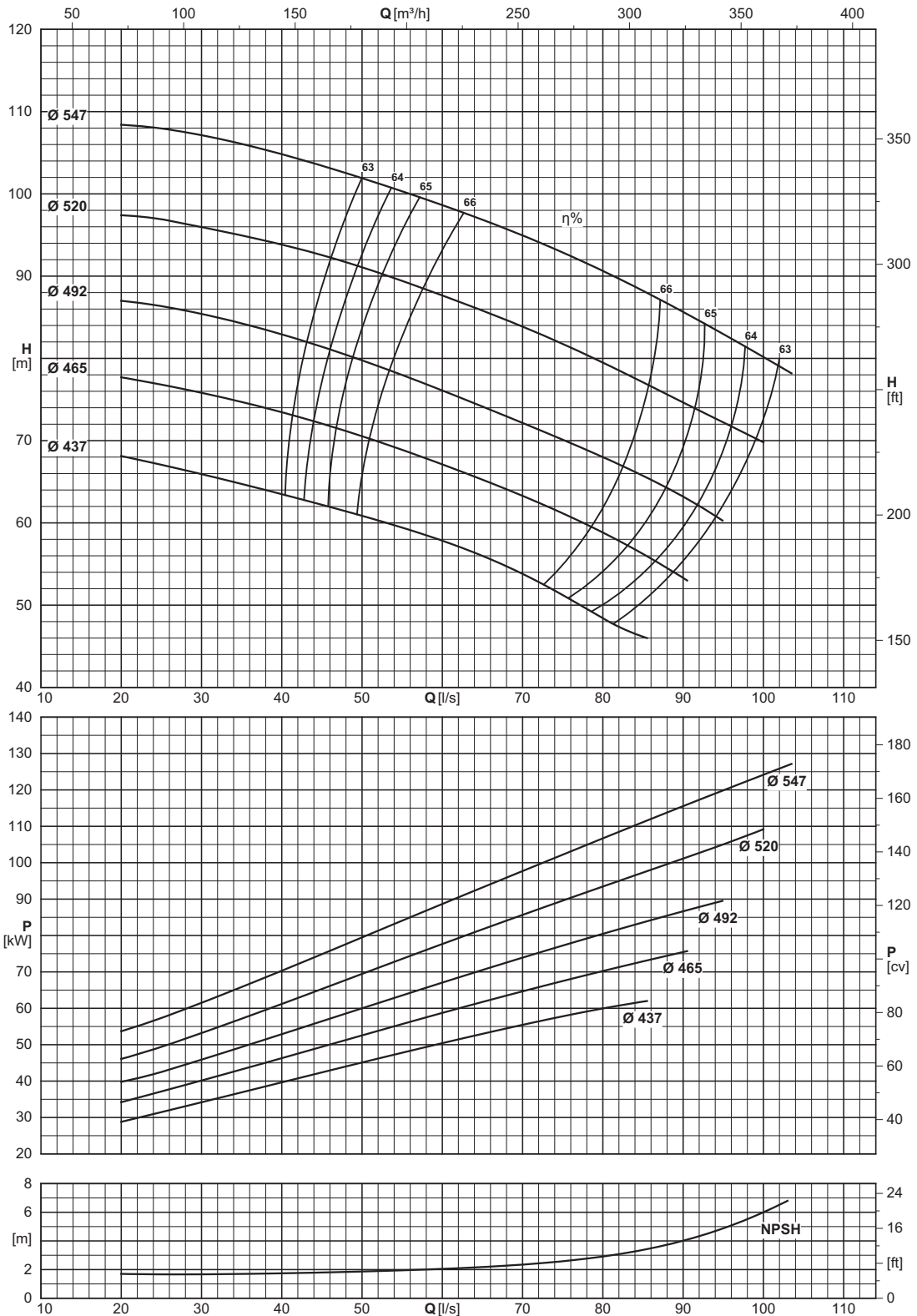

Type Тип Tipo	Inlet maximum pressure (*) Макс. давление на всасывании (*) Pressione massima in aspirazione (*)	Dynamic momentum J Динамический момент J Momento dinamico J	
		With cast iron impellers С раб. колесами из чугуна Con giranti in ghisa	With AISI 316 impellers С раб. колесами из стали AISI 316 Con giranti in AISI 316
		$J = \frac{1}{2}PD^2$	
	[bar]	[kgm ²]	
NCH125-500	0	0	(F) 0

(*) Value referred to the impeller with maximum diameter.

(*) Значение относится к раб. колесу с макс. диаметром.

(*) Valore riferito alla girante con diametro massimo.

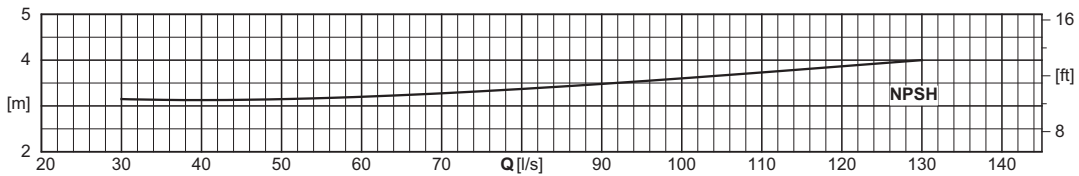
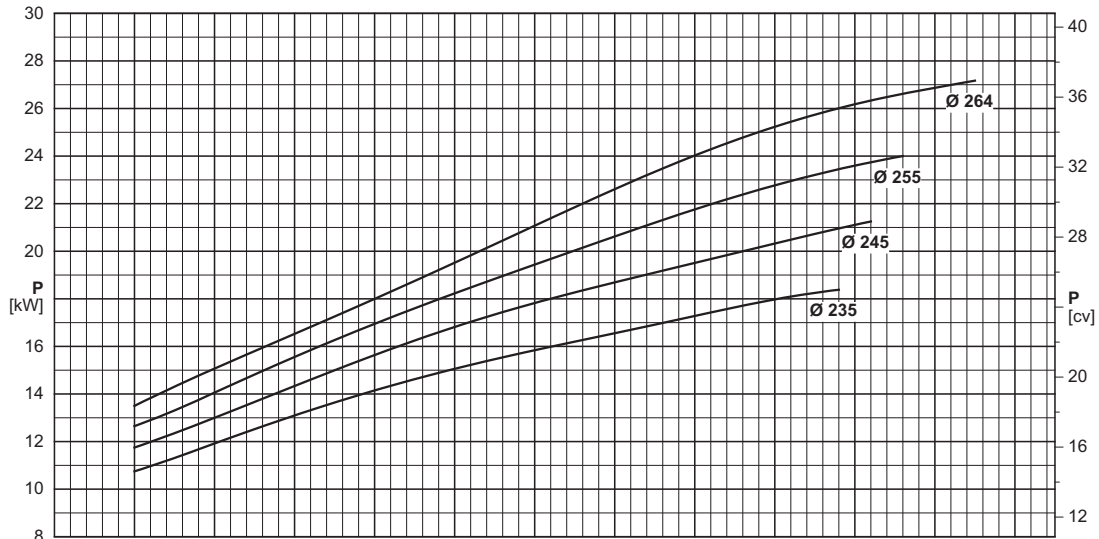
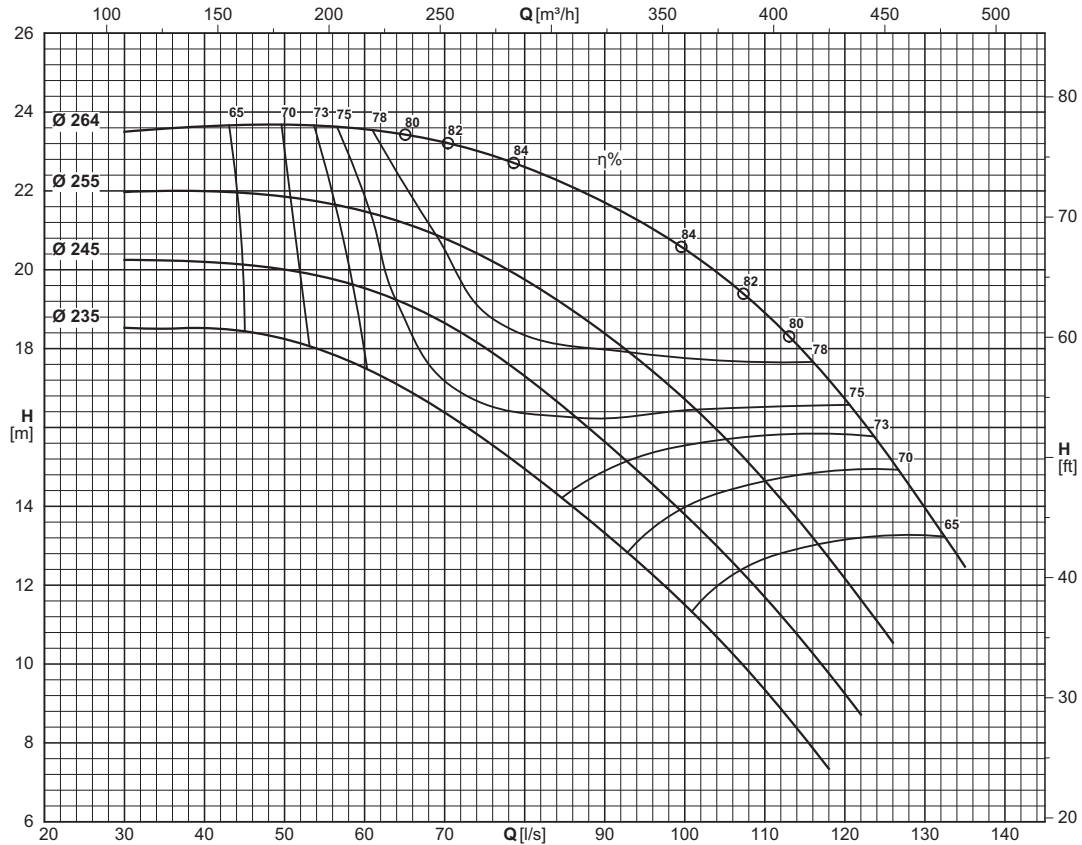

Type Тип Tipo	Inlet maximum pressure (*) Макс. давление на всасывании (*) Pressione massima in aspirazione (*)	Dynamic momentum J Динамический момент J Momento dinamico J	
		With cast iron impellers С раб. колесами из чугуна Con giranti in ghisa	With AISI 316 impellers С раб. колесами из стали AISI 316 Con giranti in AISI 316
		J = 1/4 PD ²	
	[bar]	[kgm ²]	[kgm ²]
NC150-250	6	0,0755863	(F) 0,0863843

Construction reference standard EN733 (DIN24255)
(*) Value referred to the impeller with maximum diameter.

Конструкция по стандарту EN733 (DIN24255)
(*) Значение относится к раб. колесу с макс. диаметром.

Norma di riferimento costruttivo EN733 (DIN24255)
(*) Valore riferito alla girante con diametro massimo.

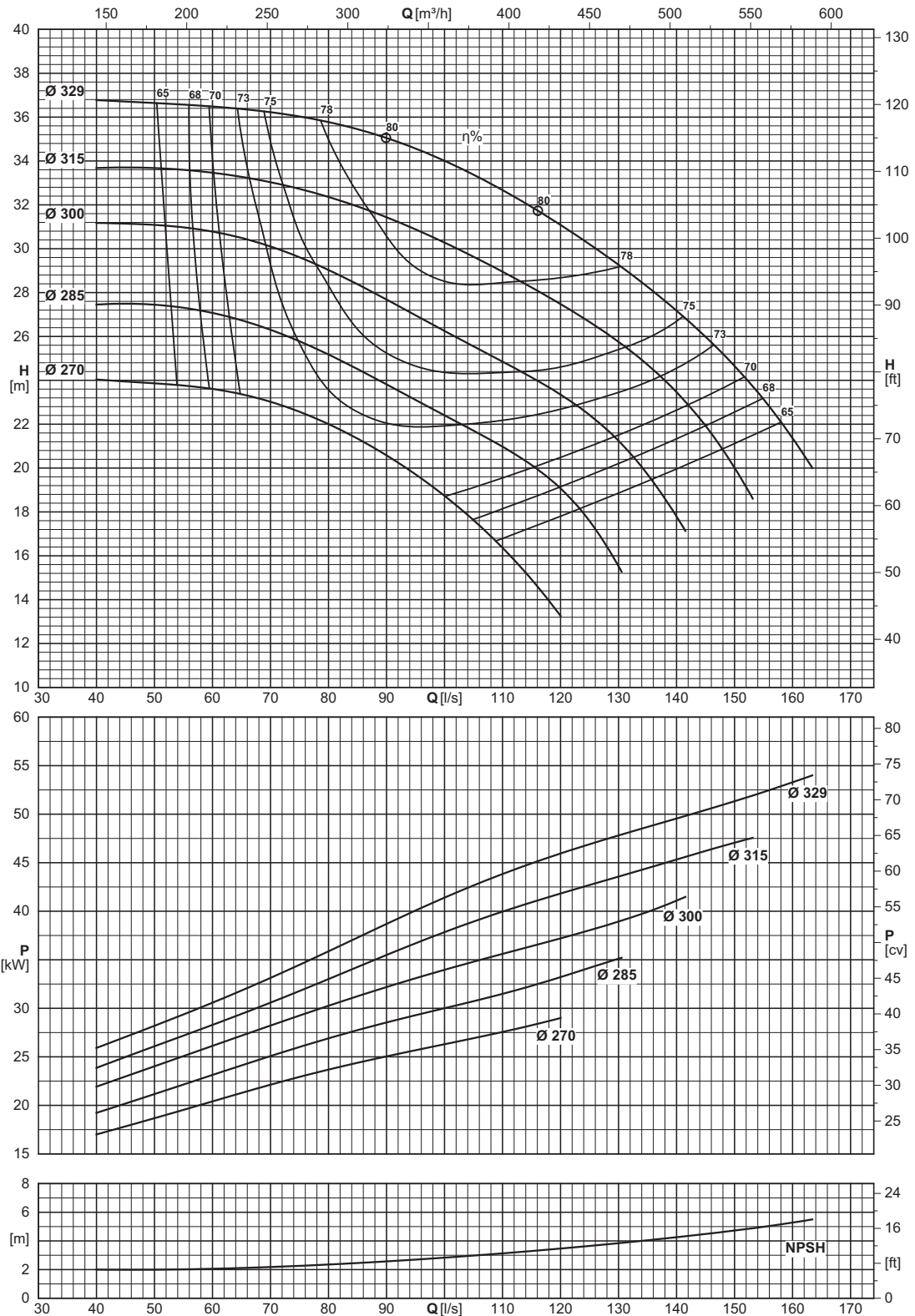

Type Тип Tipo	Inlet maximum pressure (*) Макс. давление на всасывании (*) Pressione massima in aspirazione (*)	Dynamic momentum J Динамический момент J Momento dinamico J	
		With cast iron impellers С раб. колесами из чугуна Con giranti in ghisa	With AISI 316 impellers С раб. колесами из стали AISI 316 Con giranti in AISI 316
		J=1/4PD²	
	[bar]	[kgm²]	[kgm²]
NC150-315	5	0,153559	(F) 0,175496

Construction reference standard EN733 (DIN24255)
(*) Value referred to the impeller with maximum diameter.

Конструкция по стандарту EN733 (DIN24255)
(*) Значение относится к раб. колесу с макс. диаметром.

Norma di riferimento costruttivo EN733 (DIN24255)
(*) Valore riferito alla girante con diametro massimo.

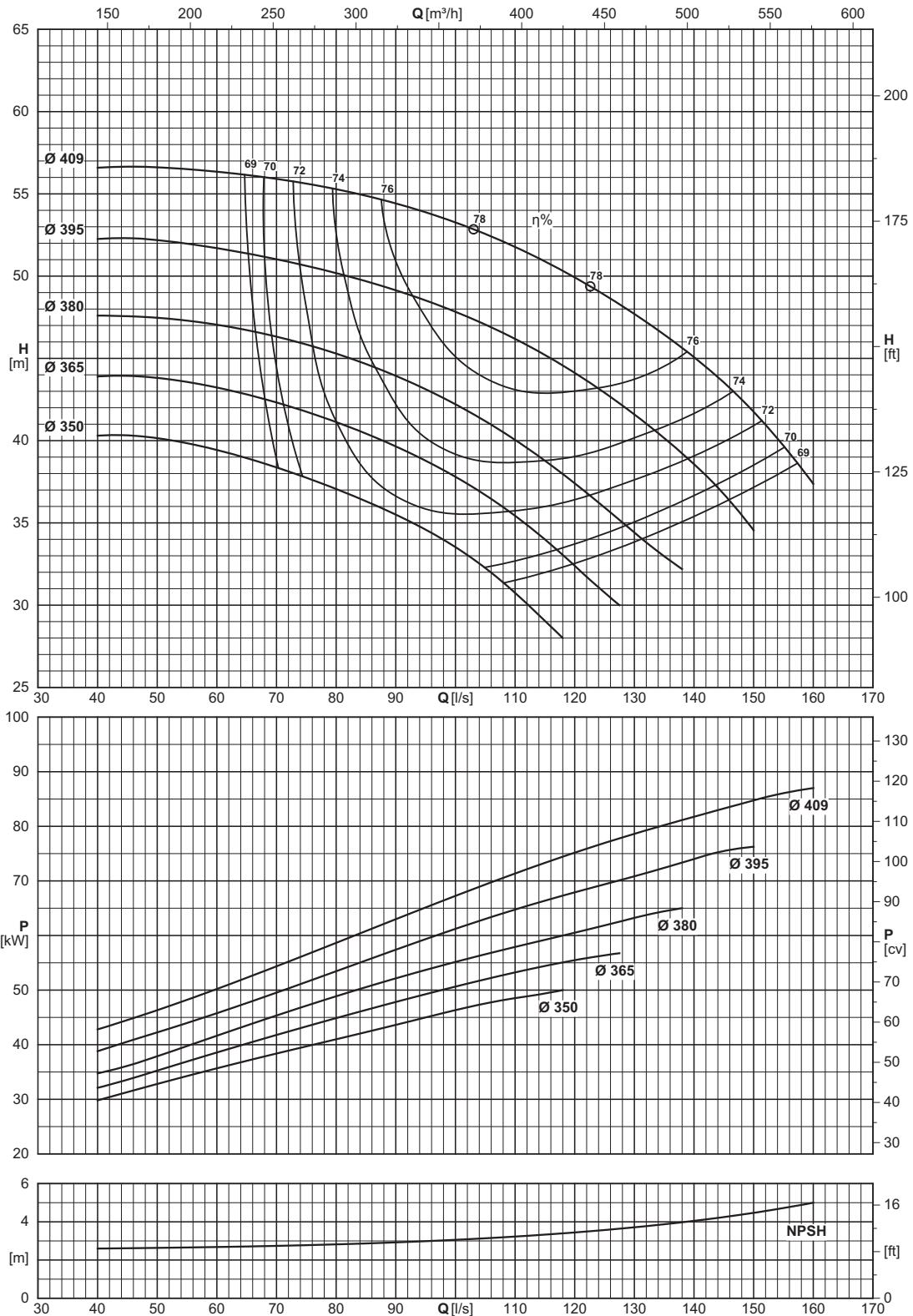

Type Тип Tipo	Inlet maximum pressure (*) Макс. давление на всасывании (*) Pressione massima in aspirazione (*)	Dinamic momentum J Динамический момент J Momento dinamico J	
		With cast iron impellers С раб. колесами из чугуна Con giranti in ghisa	With AISI 316 impellers С раб. колесами из стали AISI 316 Con giranti in AISI 316
		J = 1/4 PD ²	
	[bar]	[kgm ²]	
NC150-400	3	0,321632	(F) 0,3675795

Construction reference standard EN733 (DIN24255)
(*) Value referred to the impeller with maximum diameter.

Конструкция по стандарту EN733 (DIN24255)
(*) Значение относится к раб. колесу с макс. диаметром.

Norma di riferimento costruttivo EN733 (DIN24255)
(*) Valore riferito alla girante con diametro massimo.

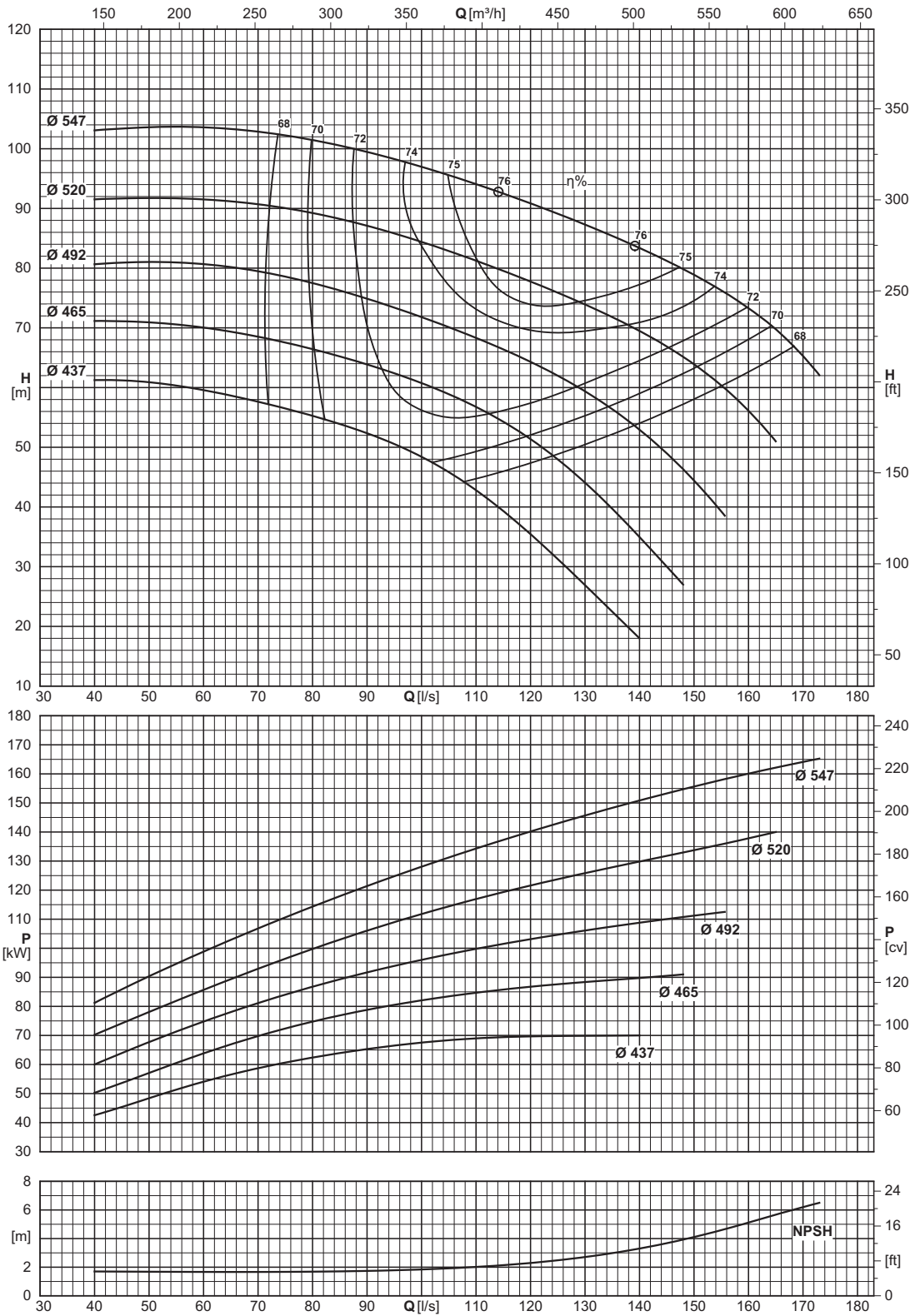

Type Тип Tipo	Inlet maximum pressure (*) Макс. давление на всасывании (*) Pressione massima in aspirazione (*)	Dynamic momentum J Динамический момент J Momento dinamico J	
		With cast iron impellers С раб. колесами из чугуна Con giranti in ghisa	With AISI 316 impellers С раб. колесами из стали AISI 316 Con giranti in AISI 316
		J=¼PD²	
	[bar]	[kgm²]	[kgm²]
NCH150-500	5	1,2431564	(F) 1,420750

(*) Value referred to the impeller with maximum diameter.

(*) Значение относится к раб. колесу с макс. диаметром.

(*) Valore riferito alla girante con diametro massimo.

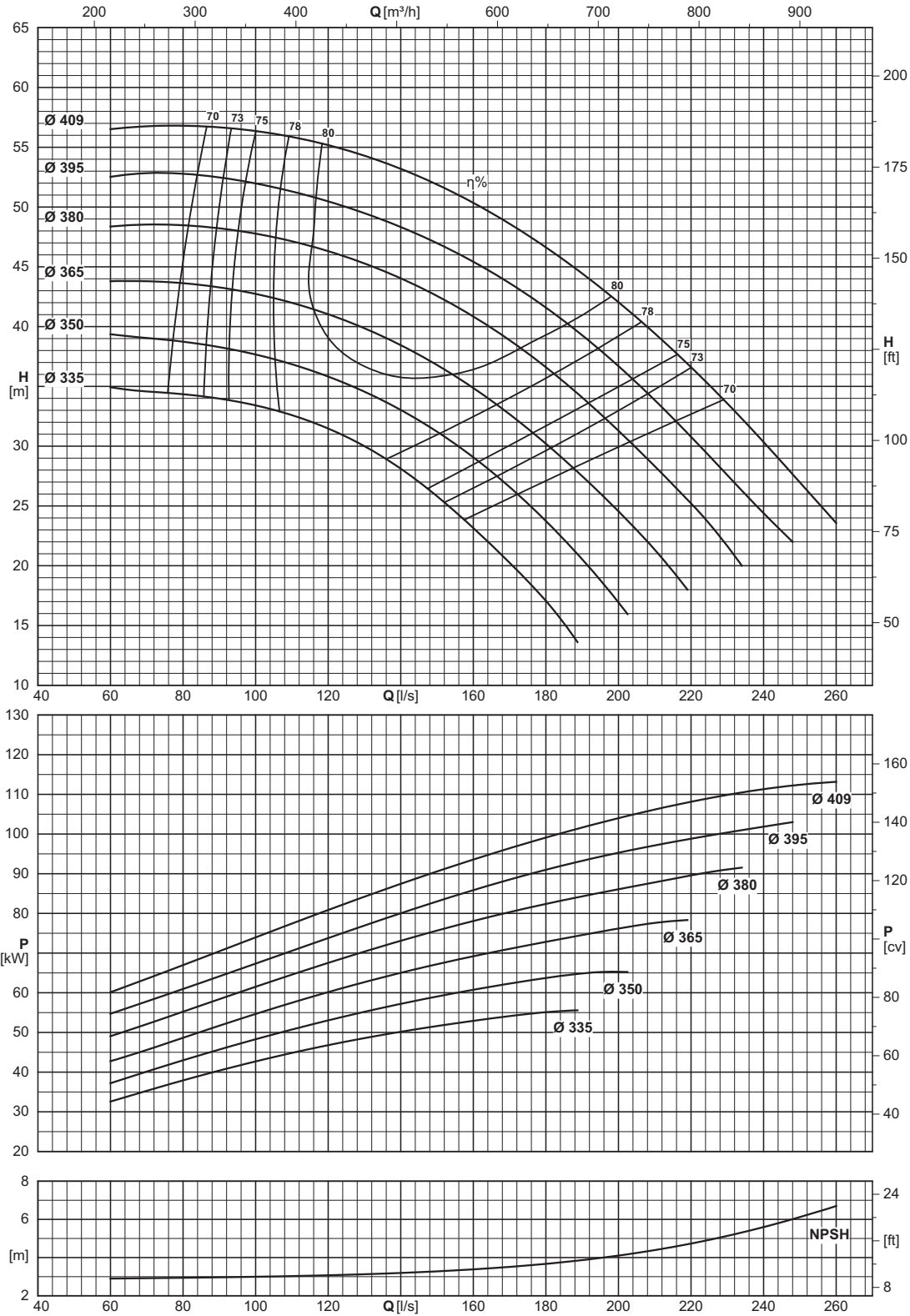

Type Тип Tipo	Inlet maximum pressure (*) Макс. давление на всасывании (*) Pressione massima in aspirazione (*)	Dynamic momentum J Динамический момент J Momento dinamico J	
		With cast iron impellers С раб. колесами из чугуна Con giranti in ghisa	With AISI 316 impellers С раб. колесами из стали AISI 316 Con giranti in AISI 316
		J=1/4PD ²	
[bar]		[kgm ²]	
NC200-400	3	0,5502445	(F) 0,6288509

(*) Value referred to the impeller with maximum diameter.

(*) Значение относится к раб. колесу с макс. диаметром.

(*) Valore riferito alla girante con diametro massimo.

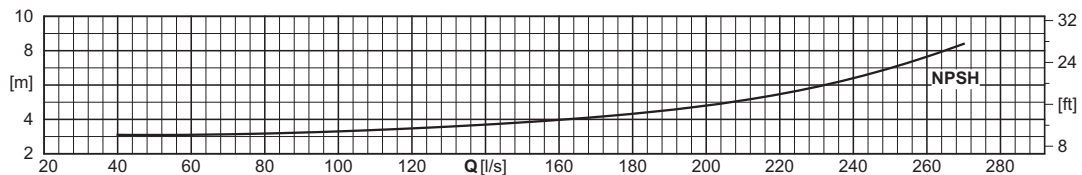
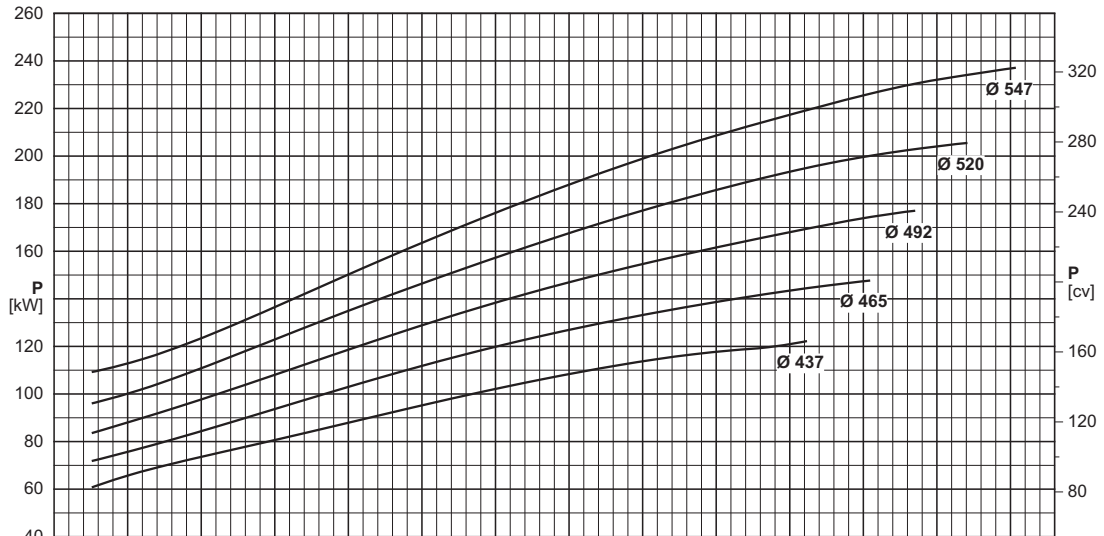
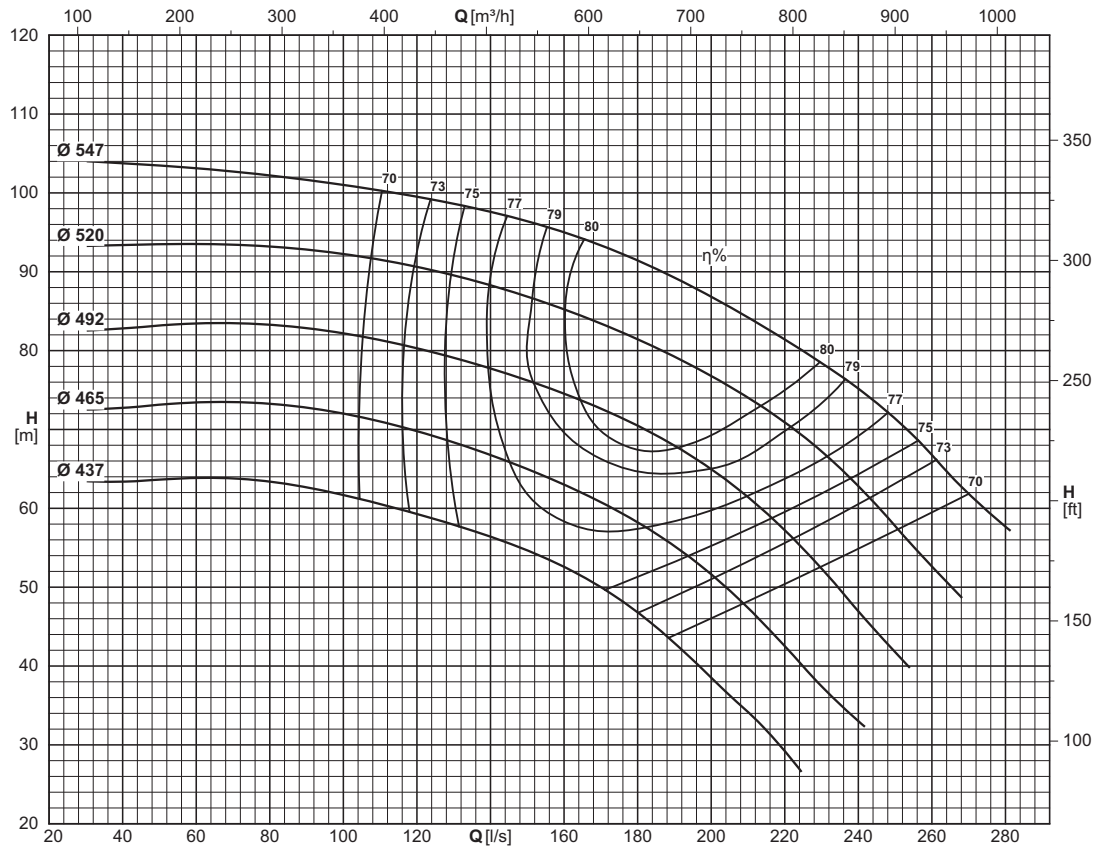

Type Тип Tipo	Inlet maximum pressure (*) Макс. давление на всасывании (*) Pressione massima in aspirazione (*)	Dynamic momentum J Динамический момент J Momento dinamico J	
		With cast iron impellers С раб. колесами из чугуна Con giranti in ghisa	With AISI 316 impellers С раб. колесами из стали AISI 316 Con giranti in AISI 316
		J=1/4PD ²	
	[bar]	[kgm ²]	(F) 0
NCH200-500	0	0	(F) 0

(*) Value referred to the impeller with maximum diameter.

(*) Значение относится к раб. колесу с макс. диаметром.

(*) Valore riferito alla girante con diametro massimo.

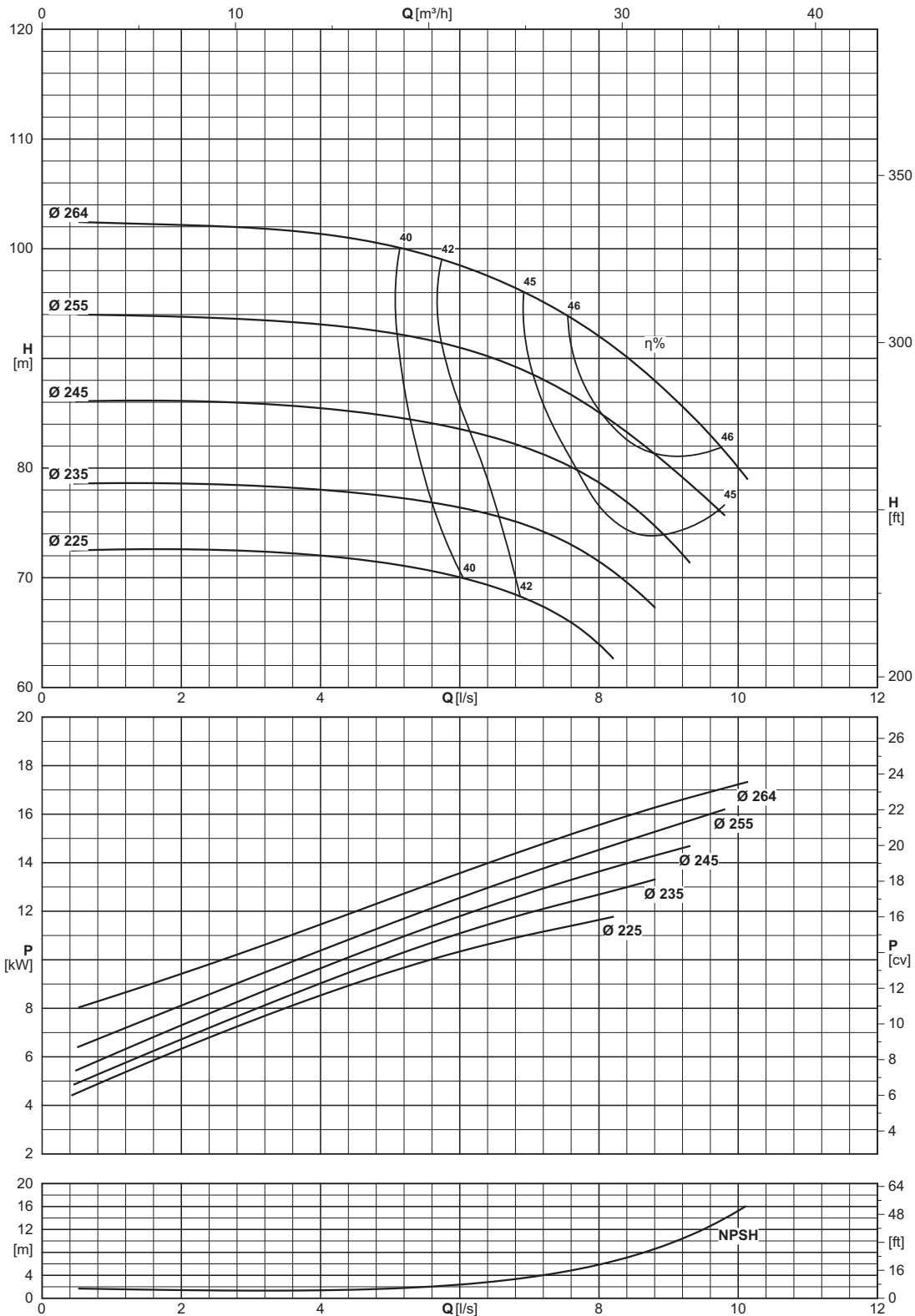

Type Тип Tipo	Inlet maximum pressure (*) Макс. давление на всасывании (*) Pressione massima in aspirazione (*)	Dynamic momentum J Динамический момент J Momento dinamico J	
		With cast iron impellers С раб. колесами из чугуна Con giranti in ghisa	With AISI 316 impellers С раб. колесами из стали AISI 316 Con giranti in AISI 316
		J=1/2 PD ²	
[bar]		[kgm ²]	
NC32-250	0	0,0297908	(F) 0,0340466

(*) Value referred to the impeller with maximum diameter.

(*) Значение относится к раб. колесу с макс. диаметром.

(*) Valore riferito alla girante con diametro massimo.

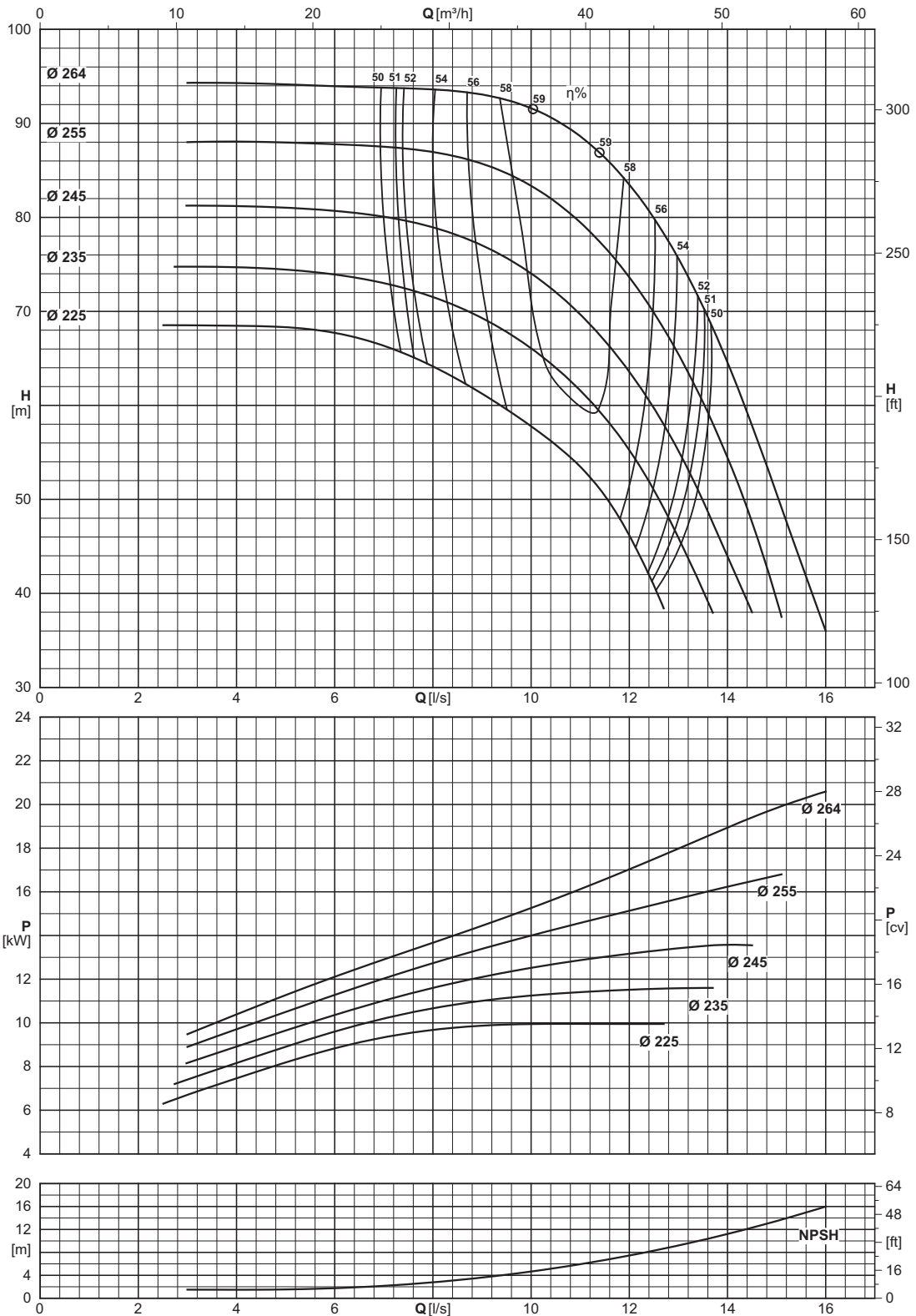

Type Тип Tipo	Inlet maximum pressure (*) Макс. давление на всасывании (*) Pressione massima in aspirazione (*)	Dynamic momentum J Динамический момент J Momento dinamico J	
		With cast iron impellers С раб. колесами из чугуна Con giranti in ghisa	With AISI 316 impellers С раб. колесами из стали AISI 316 Con giranti in AISI 316
		J=1/4PD ²	
	[bar]	[kgm ²]	[kgm ²]
NC40-250	0	0,0411814	(F) 0,0470645

Construction reference standard EN733 (DIN24255)
(*) Value referred to the impeller with maximum diameter.

Конструкция по стандарту EN733 (DIN24255)
(*) Значение относится к раб. колесу с макс. диаметром.

Norma di riferimento costruttivo EN733 (DIN24255)
(*) Valore riferito alla girante con diametro massimo.

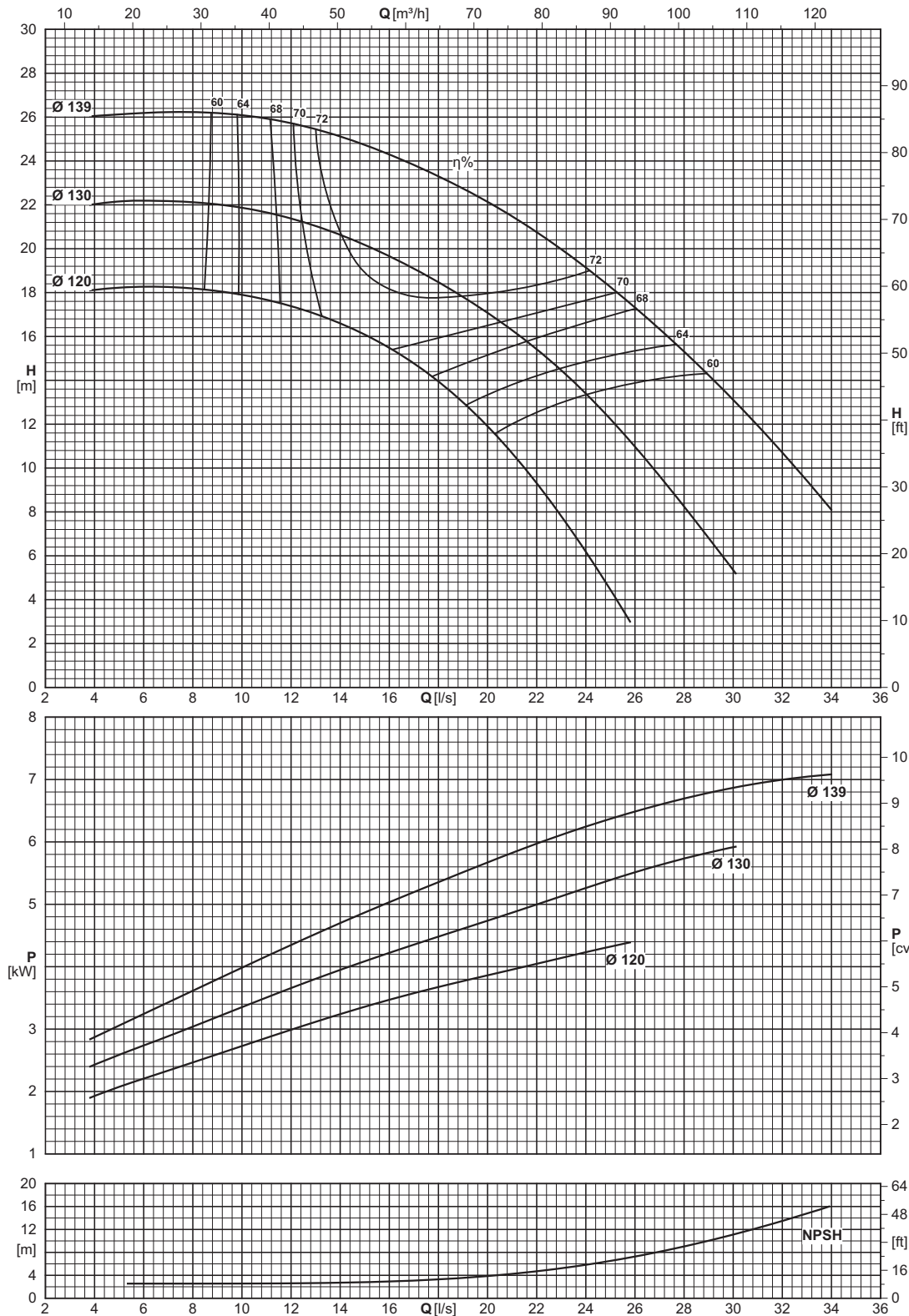

Type Тип Tipo	Inlet maximum pressure (*) Макс. давление на всасывании (*) Pressione massima in aspirazione (*)	Dinamic momentum J Динамический момент J Momento dinamico J	
		With cast iron impellers С раб. колесами из чугуна Con giranti in ghisa	With AISI 316 impellers С раб. колесами из стали AISI 316 Con giranti in AISI 316
		J = 1/4 PD ²	
	[bar]	[kgm ²]	
NC50-125	6	0,0036977	(F) 0,0042259

Construction reference standard EN733 (DIN24255)
(*) Value referred to the impeller with maximum diameter.

Конструкция по стандарту EN733 (DIN24255)
(*) Значение относится к раб. колесу с макс. диаметром.

Norma di riferimento costruttivo EN733 (DIN24255)
(*) Valore riferito alla girante con diametro massimo.

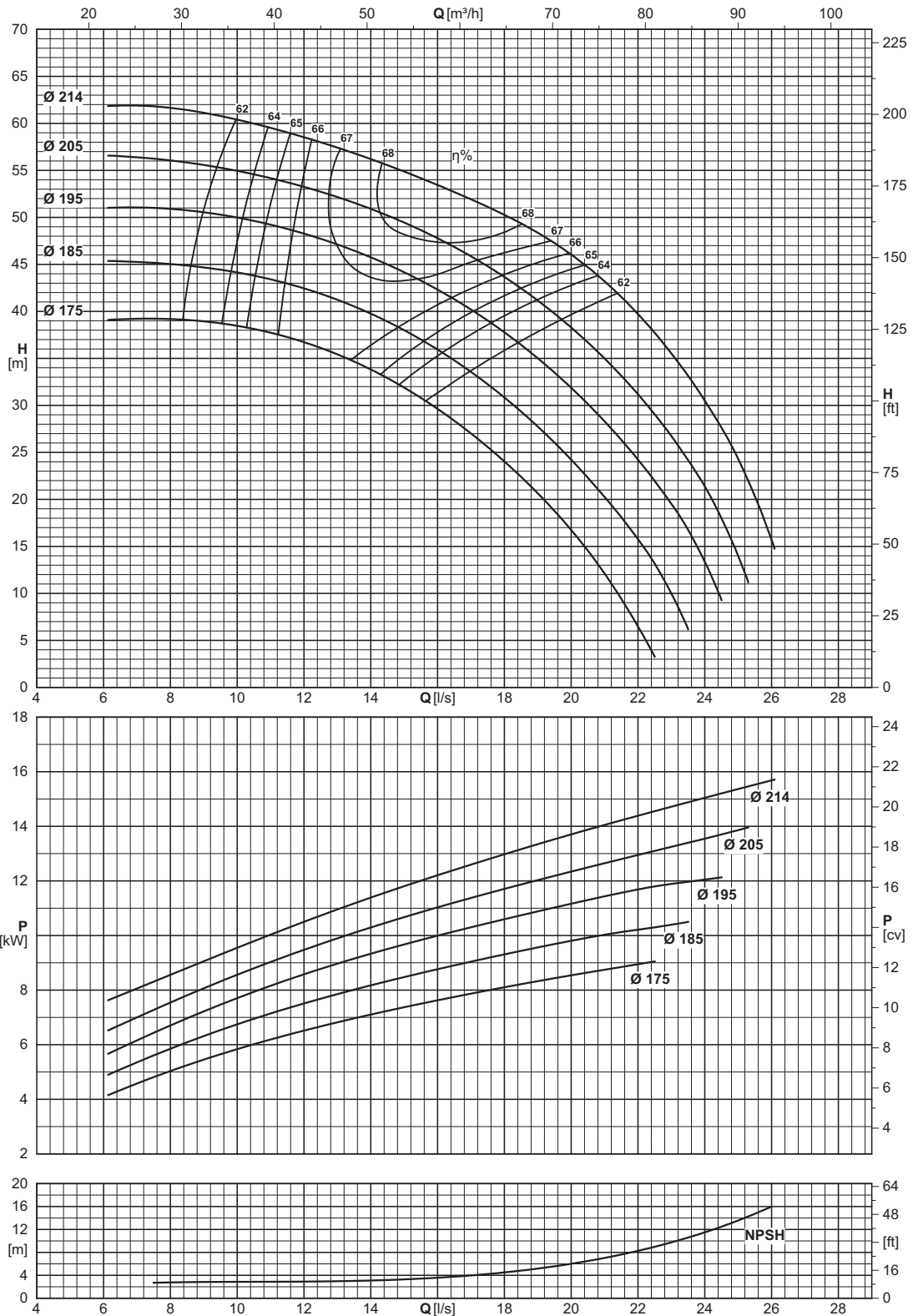

Type Тип Tipo	Inlet maximum pressure (*) Макс. давление на всасывании (*) Pressione massima in aspirazione (*)	Dynamic momentum J Динамический момент J Momento dinamico J	
		With cast iron impellers С раб. колесами из чугуна Con giranti in ghisa	With AISI 316 impellers С раб. колесами из стали AISI 316 Con giranti in AISI 316
		$J = \frac{1}{4}PD^2$	
	[bar]	[kgm ²]	
NC50-200	2	0,0158799	(F) 0,0181484

Construction reference standard EN733 (DIN24255)
(*) Value referred to the impeller with maximum diameter.

Конструкция по стандарту EN733 (DIN24255)
(*) Значение относится к раб. колесу с макс. диаметром.

Norma di riferimento costruttivo EN733 (DIN24255)
(*) Valore riferito alla girante con diametro massimo.

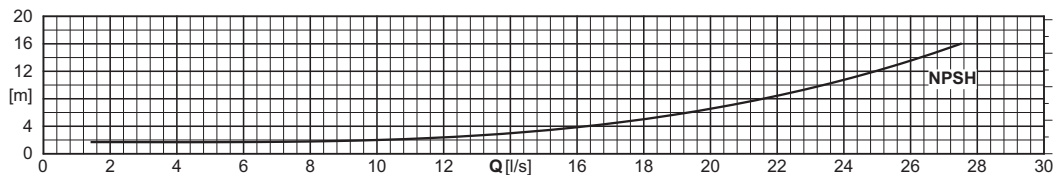
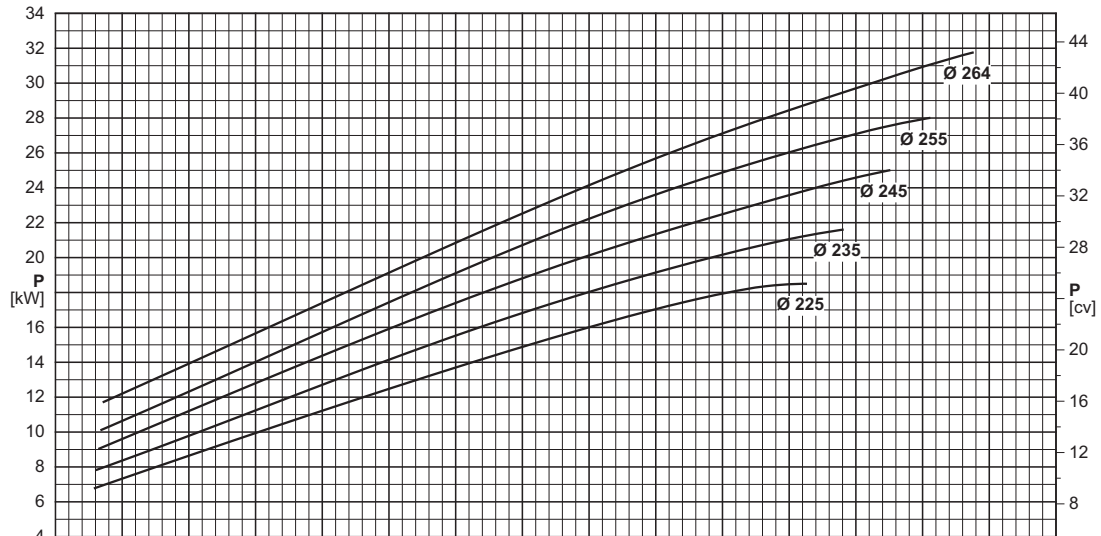
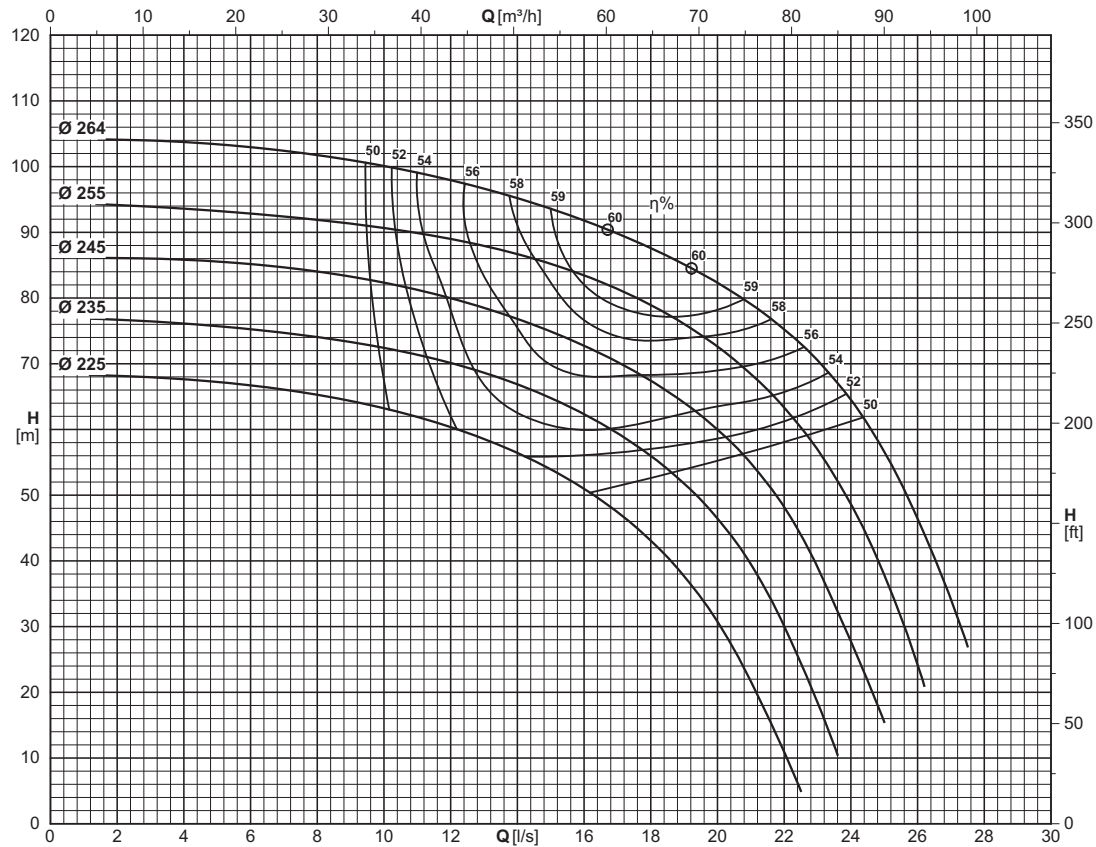

Type Тип Tipo	Inlet maximum pressure (*) Макс. давление на всасывании (*) Pressione massima in aspirazione (*)	Dynamic momentum J Динамический момент J Momento dinamico J	
		With cast iron impellers С раб. колесами из чугуна Con giranti in ghisa	With AISI 316 impellers С раб. колесами из стали AISI 316 Con giranti in AISI 316
		J = 1/4 PD ²	
	[bar]	[kgm ²]	
NC50-250	0	0,0385528	(F) 0,0440603

Construction reference standard EN733 (DIN24255)
(*) Value referred to the impeller with maximum diameter.

Конструкция по стандарту EN733 (DIN24255)
(*) Значение относится к раб. колесу с макс. диаметром.

Norma di riferimento costruttivo EN733 (DIN24255)
(*) Valore riferito alla girante con diametro massimo.

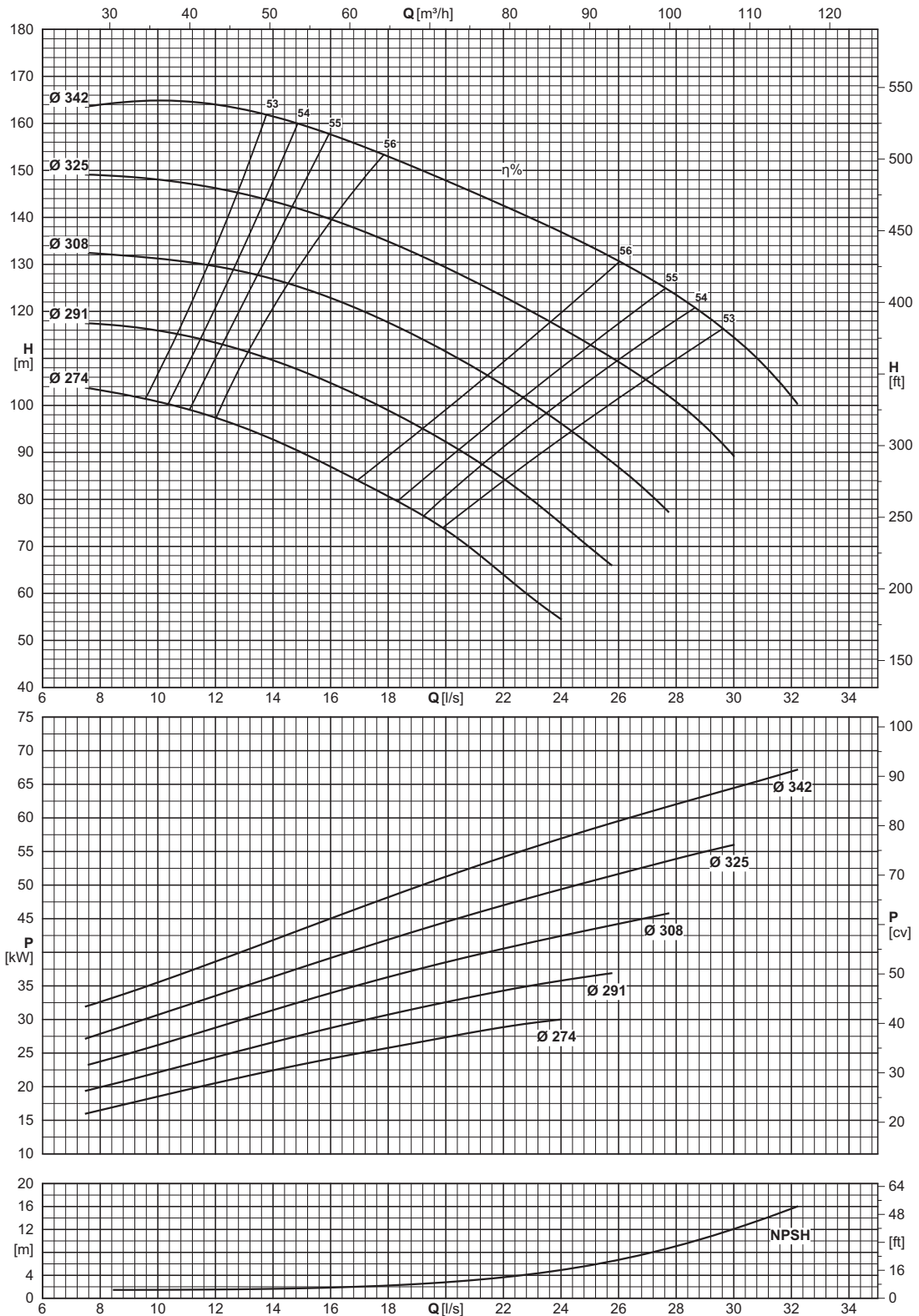

Type Тип Tipo	Inlet maximum pressure (*) Макс. давление на всасывании (*) Pressione massima in aspirazione (*)	Dynamic momentum J Динамический момент J Momento dinamico J	
		With cast iron impellers С раб. колесами из чугуна Con giranti in ghisa	With AISI 316 impellers С раб. колесами из стали AISI 316 Con giranti in AISI 316
		$J = \frac{1}{4}PD^2$	
	[bar]	[kgm ²]	
NCH50-315	8	0,147485	(F) 0,1685543

(*) Value referred to the impeller with maximum diameter.

(*) Значение относится к раб. колесу с макс. диаметром.

(*) Valore riferito alla girante con diametro massimo.

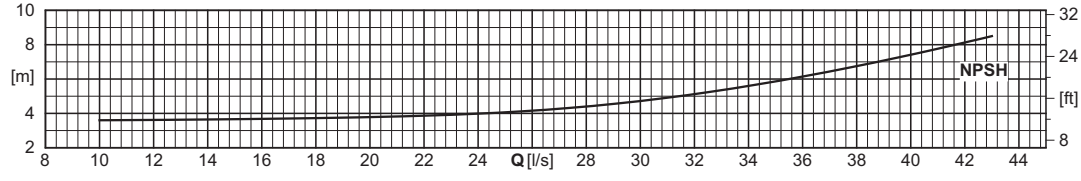
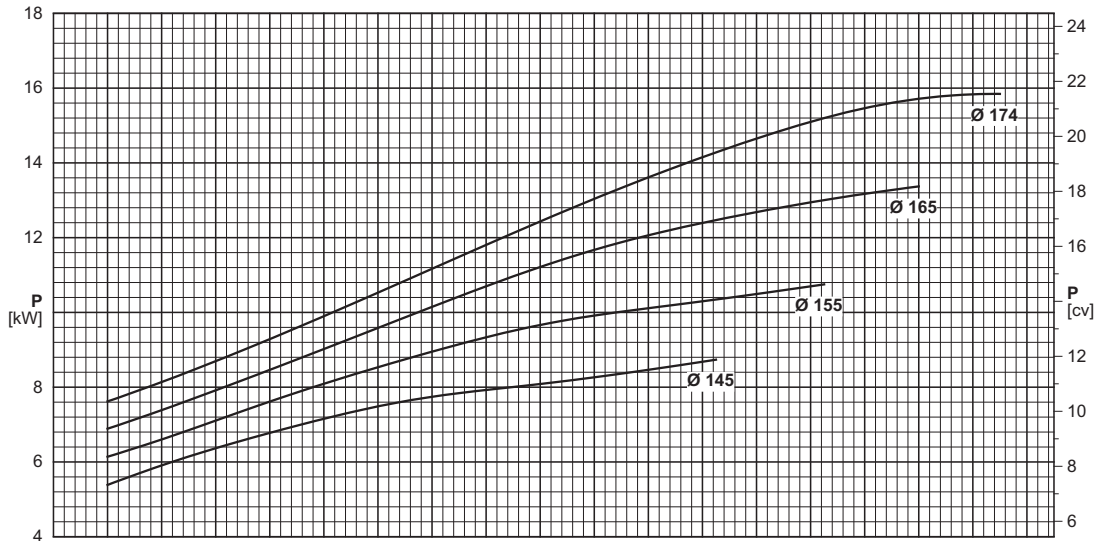
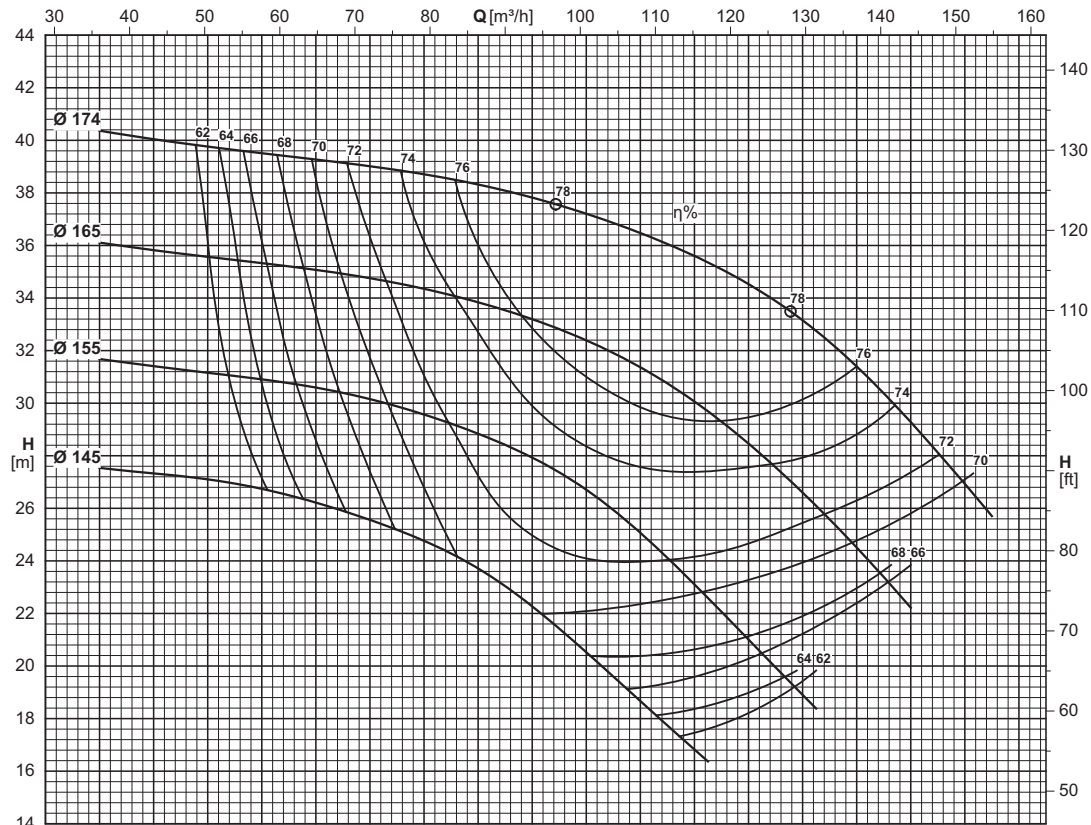

Type Тип Tipo	Inlet maximum pressure (*) Макс. давление на всасывании (*) Pressione massima in aspirazione (*)	Dynamic momentum J Динамический момент J Momento dinamico J	
		With cast iron impellers С раб. колесами из чугуна Con giranti in ghisa	With AISI 316 impellers С раб. колесами из стали AISI 316 Con giranti in AISI 316
		J = 1/4 PD ²	
	[bar]	[kgm ²]	
NC65-160	5	0,0078607	(F) 0,0089837

Construction reference standard EN733 (DIN24255)
(*) Value referred to the impeller with maximum diameter.

Конструкция по стандарту EN733 (DIN24255)
(*) Значение относится к раб. колесу с макс. диаметром.

Norma di riferimento costruttivo EN733 (DIN24255)
(*) Valore riferito alla girante con diametro massimo.

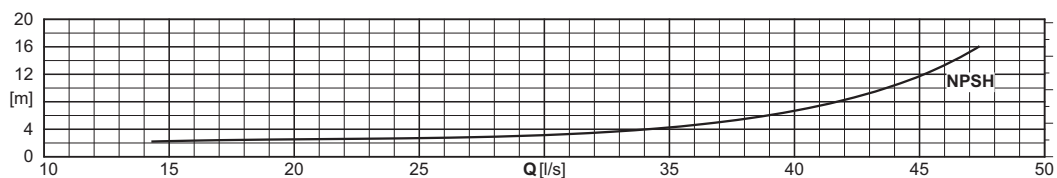
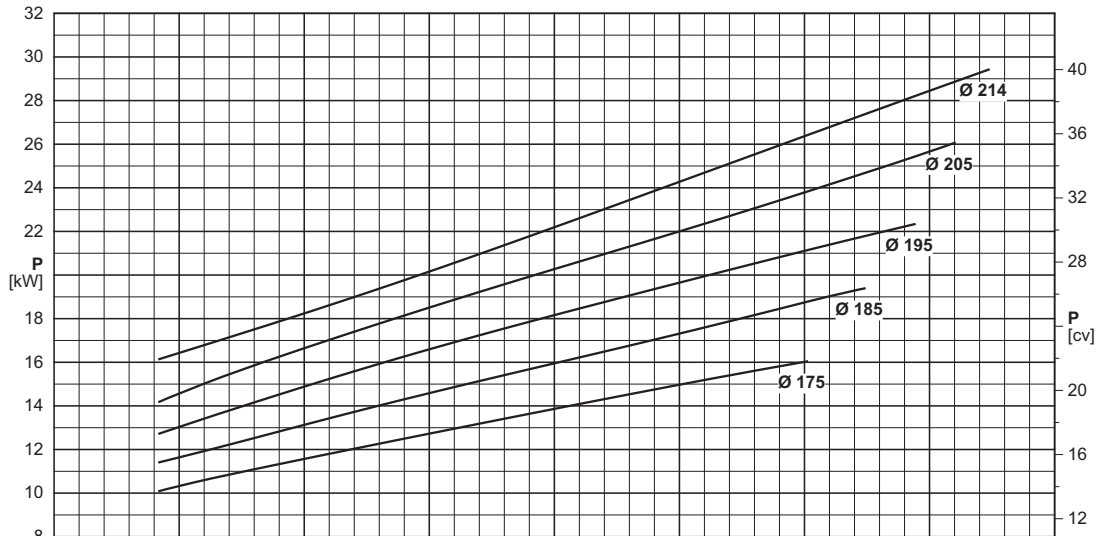
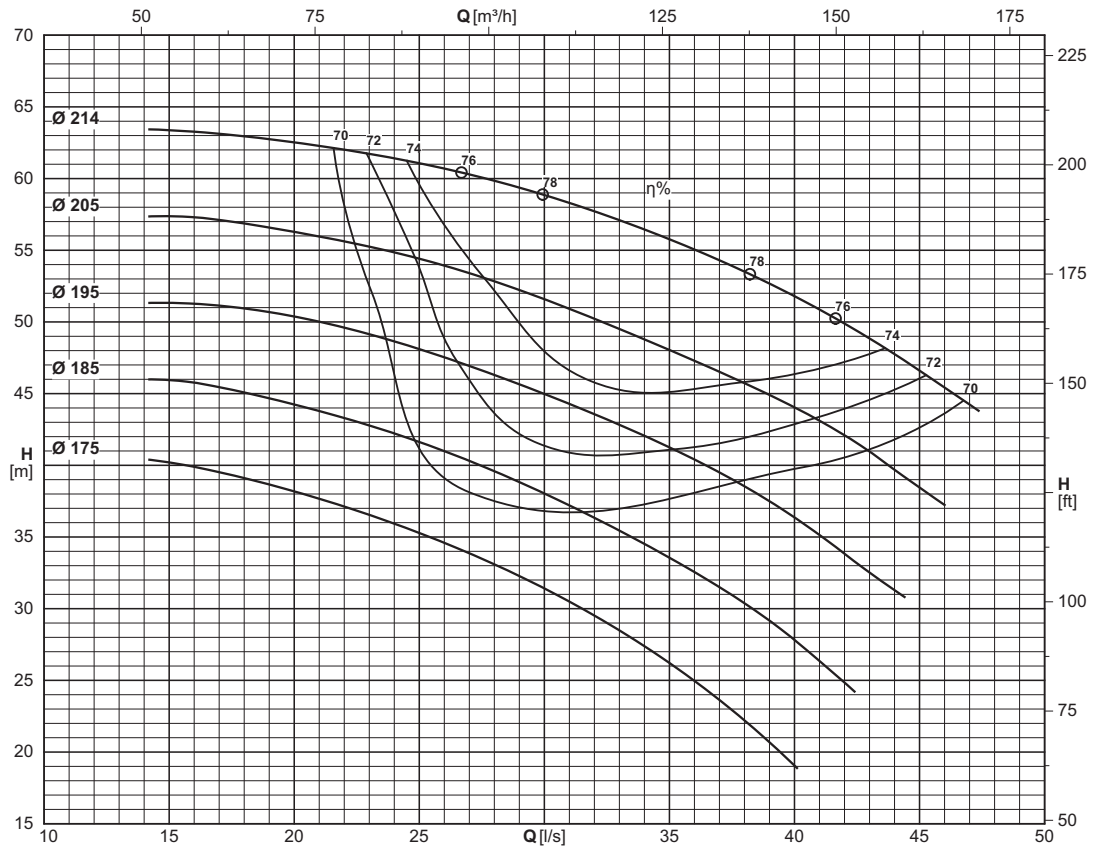

Type Тип Tipo	Inlet maximum pressure (*) Макс. давление на всасывании (*) Pressione massima in aspirazione (*)	Dynamic momentum J Динамический момент J Momento dinamico J	
		With cast iron impellers С раб. колесами из чугуна Con giranti in ghisa	With AISI 316 impellers С раб. колесами из стали AISI 316 Con giranti in AISI 316
		J=1/4PD ²	
[bar]		[kgm ²]	
NC65-200	2	0,0158799	(F) 0,0181484

Construction reference standard EN733 (DIN24255)
(*) Value referred to the impeller with maximum diameter.

Конструкция по стандарту EN733 (DIN24255)
(*) Значение относится к раб. колесу с макс. диаметром.

Norma di riferimento costruttivo EN733 (DIN24255)
(*) Valore riferito alla girante con diametro massimo.

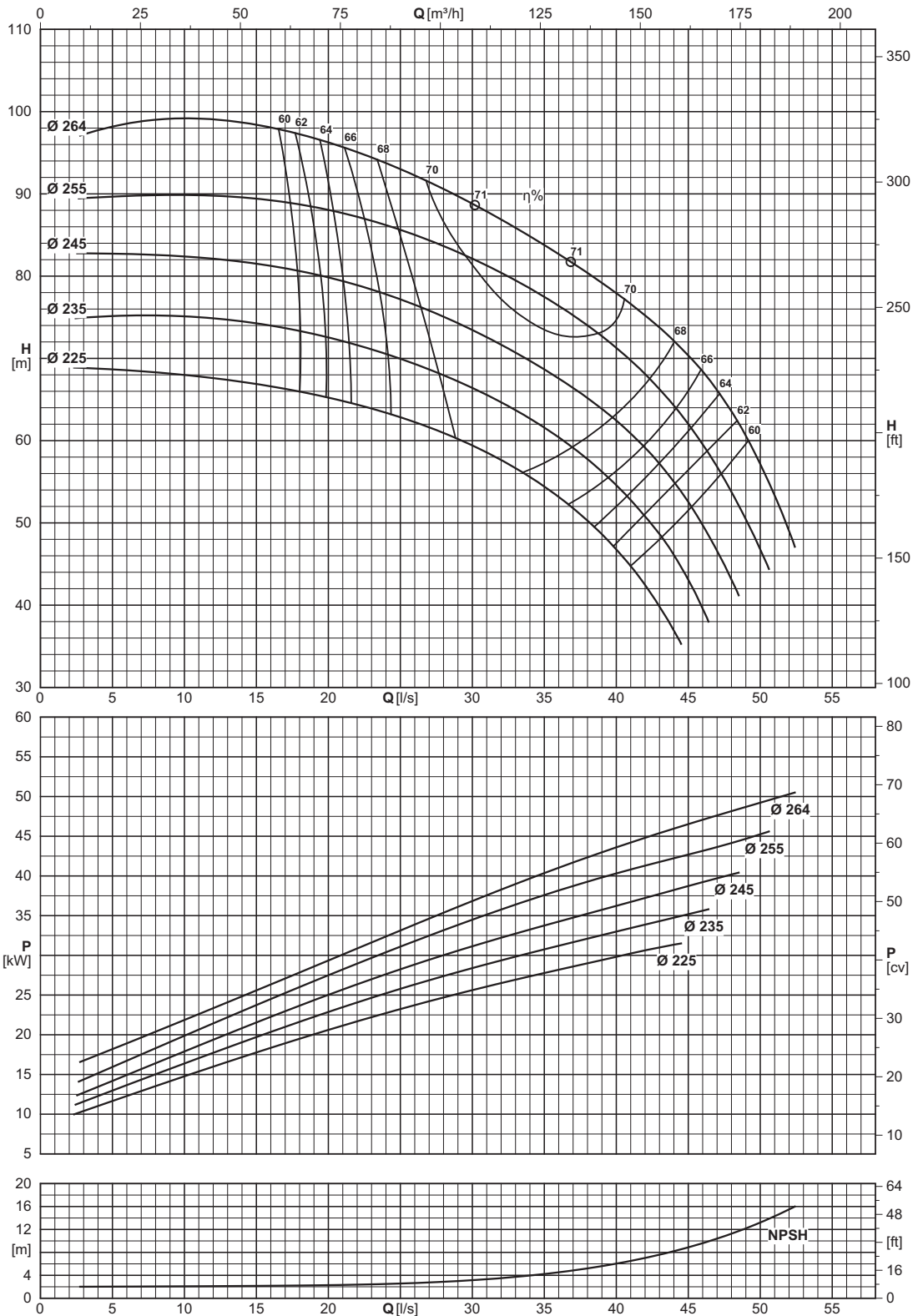

Type Тип Tipo	Inlet maximum pressure (*) Макс. давление на всасывании (*) Pressione massima in aspirazione (*)	Dynamic momentum J Динамический момент J Momento dinamico J	
		With cast iron impellers С раб. колесами из чугуна Con giranti in ghisa	With AISI 316 impellers С раб. колесами из стали AISI 316 Con giranti in AISI 316
		J=1/2 PD ²	
	[bar]	[kgm ²]	
NC65-250	0	0,04405	(F) 0,0503429

Construction reference standard EN733 (DIN24255)
(*) Value referred to the impeller with maximum diameter.

Конструкция по стандарту EN733 (DIN24255)
(*) Значение относится к раб. колесу с макс. диаметром.

Norma di riferimento costruttivo EN733 (DIN24255)
(*) Valore riferito alla girante con diametro massimo.

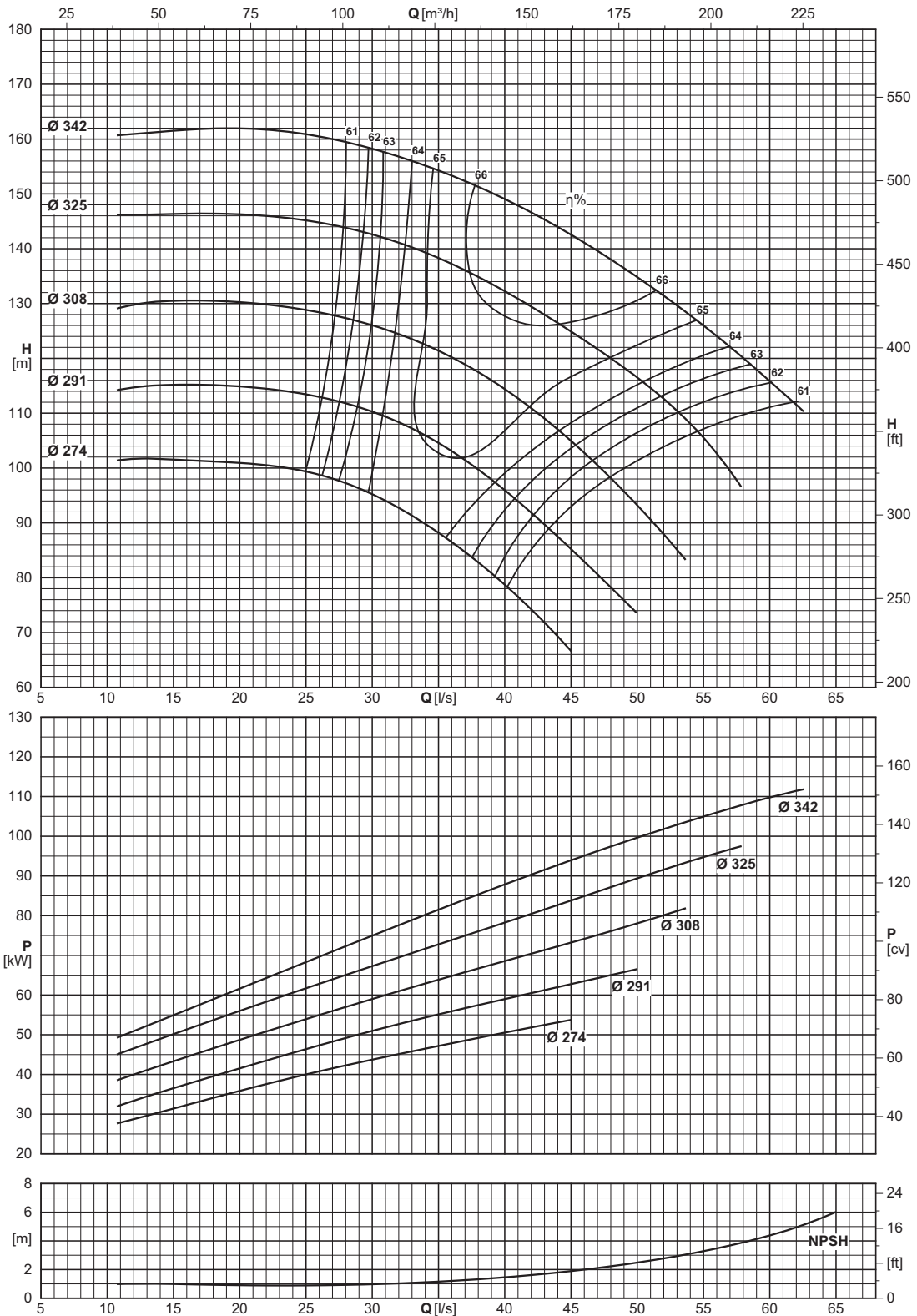

Type Тип Tipo	Inlet maximum pressure (*) Макс. давление на всасывании (*) Pressione massima in aspirazione (*)	Dynamic momentum J Динамический момент J Momento dinamico J	
		With cast iron impellers С раб. колесами из чугуна Con giranti in ghisa	With AISI 316 impellers С раб. колесами из стали AISI 316 Con giranti in AISI 316
		J = 1/4 PD ²	
[bar]		[kgm ²]	
NCH65-315	0	0,1630808	(F) 0,1863781

(*) Value referred to the impeller with maximum diameter.

(*) Значение относится к раб. колесу с макс. диаметром.

(*) Valore riferito alla girante con diametro massimo.

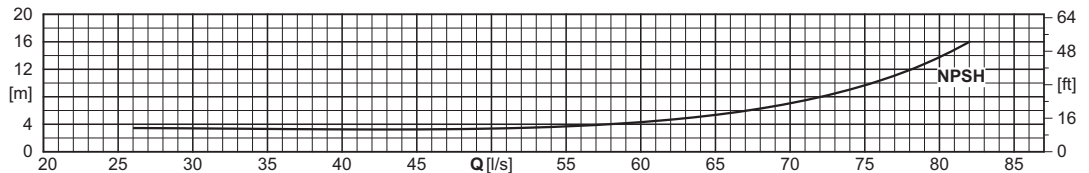
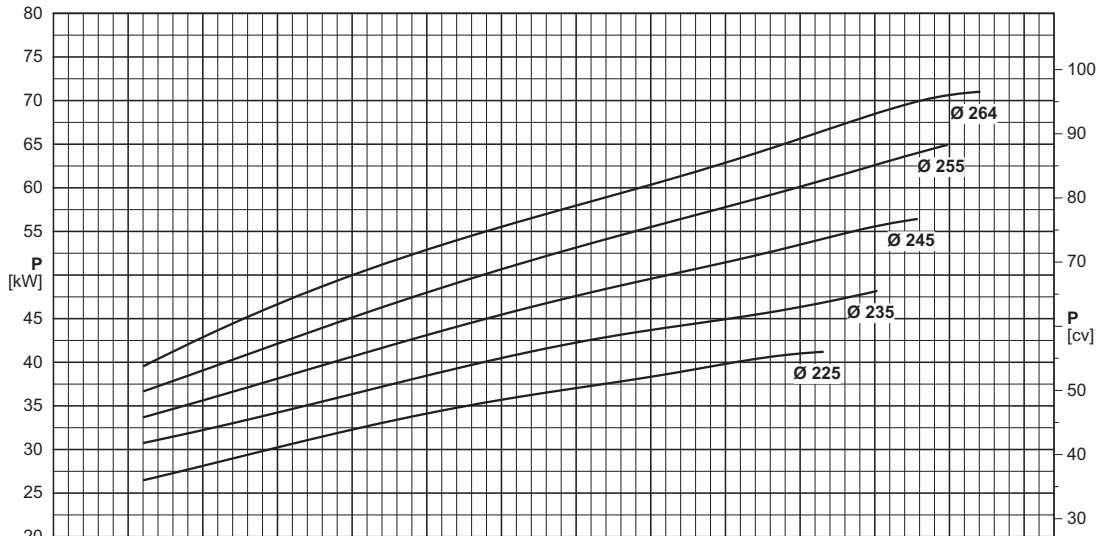
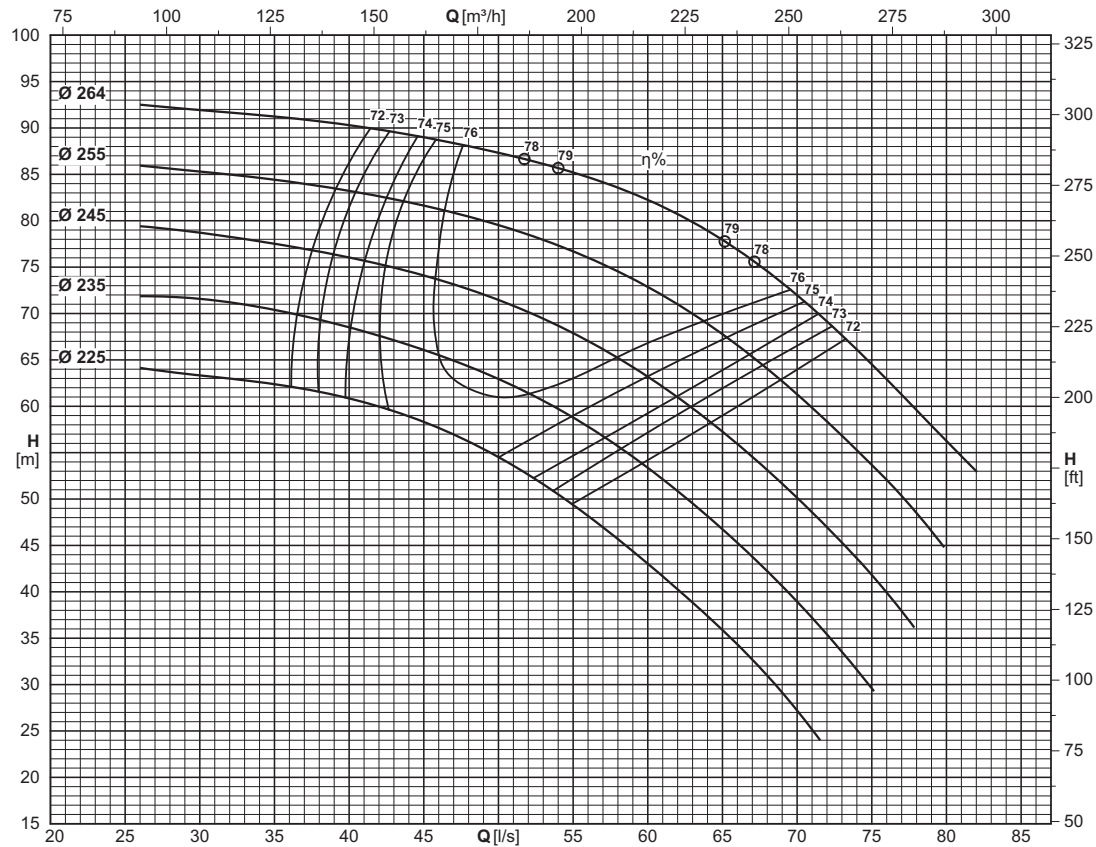

Type Тип Tipo	Inlet maximum pressure (*) Макс. давление на всасывании (*) Pressione massima in aspirazione (*)	Dinamic momentum J Динамический момент J Momento dinamico J	
		With cast iron impellers С раб. колесами из чугуна Con giranti in ghisa	With AISI 316 impellers С раб. колесами из стали AISI 316 Con giranti in AISI 316
		J=1/4PD ²	
	[bar]	[kgm ²]	[kgm ²]
NC80-250	0	0,0427285	(F) 0,0488326

Construction reference standard EN733 (DIN24255)
(*) Value referred to the impeller with maximum diameter.

Конструкция по стандарту EN733 (DIN24255)
(*) Значение относится к раб. колесу с макс. диаметром.

Norma di riferimento costruttivo EN733 (DIN24255)
(*) Valore riferito alla girante con diametro massimo.

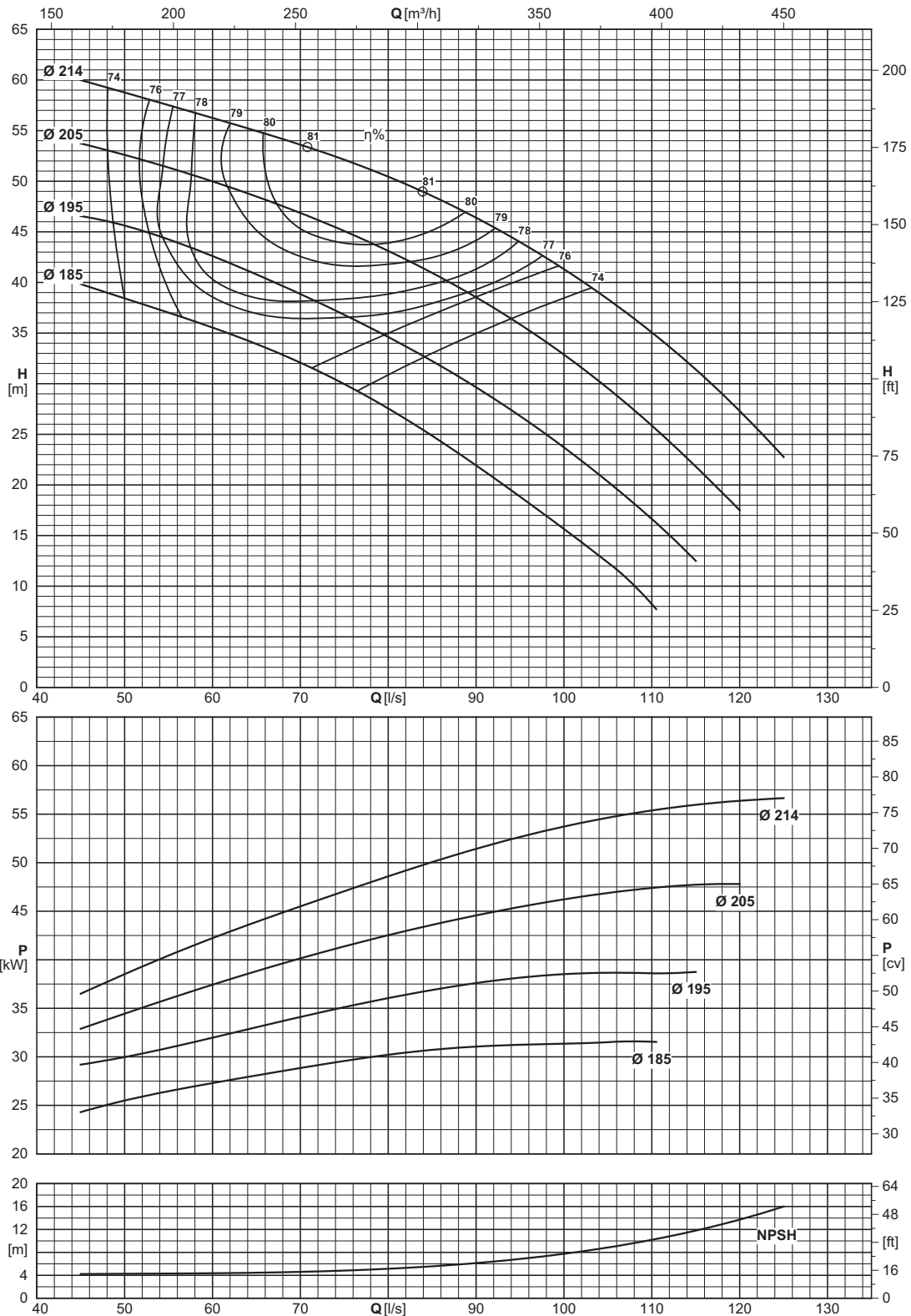

Type Тип Tipo	Inlet maximum pressure (*) Макс. давление на всасывании (*) Pressione massima in aspirazione (*)	Dynamic momentum J Динамический момент J Momento dinamico J	
		With cast iron impellers С раб. колесами из чугуна Con giranti in ghisa	With AISI 316 impellers С раб. колесами из стали AISI 316 Con giranti in AISI 316
		J=1/4PD²	
	[bar]	[kgm²]	
NC100-200	3	0,0247456	(F) 0,0282807

Construction reference standard EN733 (DIN24255)
(*) Value referred to the impeller with maximum diameter.

Конструкция по стандарту EN733 (DIN24255)
(*) Значение относится к раб. колесу с макс. диаметром.

Norma di riferimento costruttivo EN733 (DIN24255)
(*) Valore riferito alla girante con diametro massimo.

NCH 100-315

2900 n [min⁻¹]



Operating data
Рабочие характеристики
Caratteristiche di funzionamento

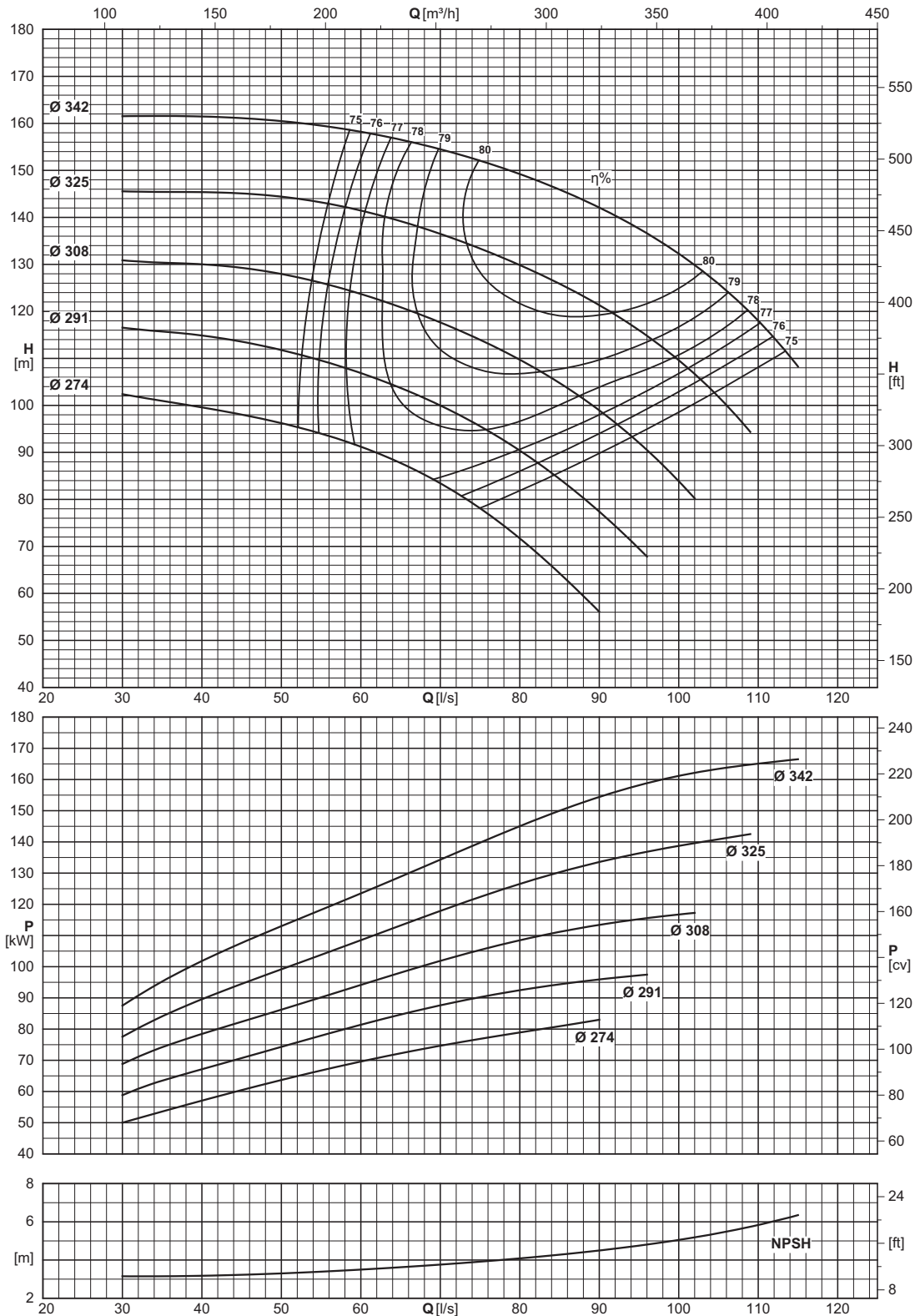

Type Тип Tipo	Inlet maximum pressure (*) Макс. давление на всасывании (*) Pressione massima in aspirazione (*)	Dynamic momentum J Динамический момент J Momento dinamico J	
		With cast iron impellers С раб. колесами из чугуна Con giranti in ghisa	With AISI 316 impellers С раб. колесами из стали AISI 316 Con giranti in AISI 316
		J=1/4PD²	
[bar]		[kgm²]	
NCH100-315	0	0,1779064	(F) 0,2033216

(*) Value referred to the impeller with maximum diameter.

(*) Значение относится к раб. колесу с макс. диаметром.

(*) Valore riferito alla girante con diametro massimo.

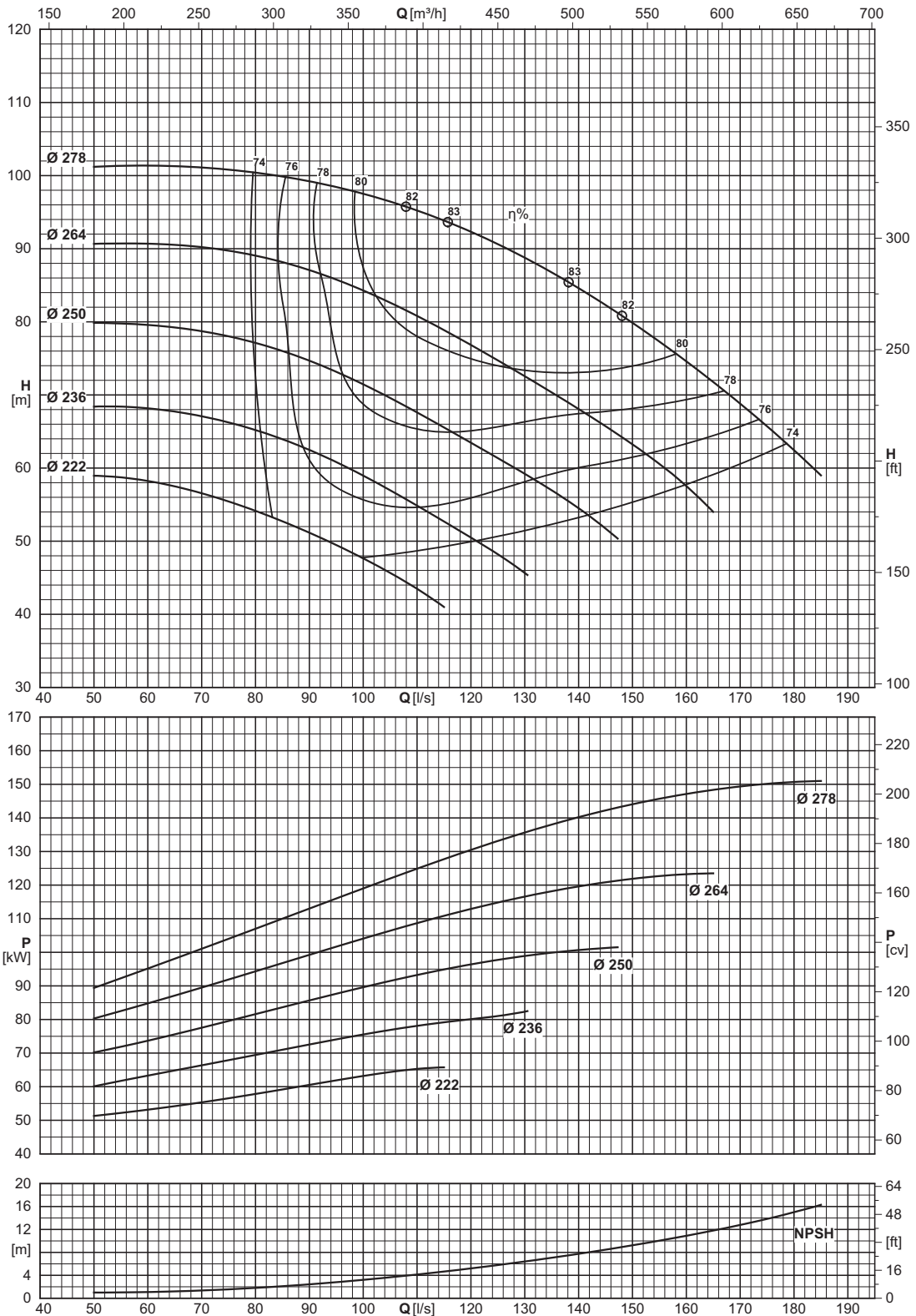

Type Тип Tipo	Inlet maximum pressure (*) Макс. давление на всасывании (*) Pressione massima in aspirazione (*)	Dynamic momentum J Динамический момент J Momento dinamico J	
		With cast iron impellers С раб. колесами из чугуна Con giranti in ghisa	With AISI 316 impellers С раб. колесами из стали AISI 316 Con giranti in AISI 316
		J = 1/4 PD ²	
	[bar]	[kgm ²]	[kgm ²]
NCH125-250	5	0,0986553	(F) 0,1127489

(*) Value referred to the impeller with maximum diameter.

(*) Значение относится к раб. колесу с макс. диаметром.

(*) Valore riferito alla girante con diametro massimo.

Overall dimensions and weights
 Общие габариты и вес
 Dimensioni di ingombro e pesi

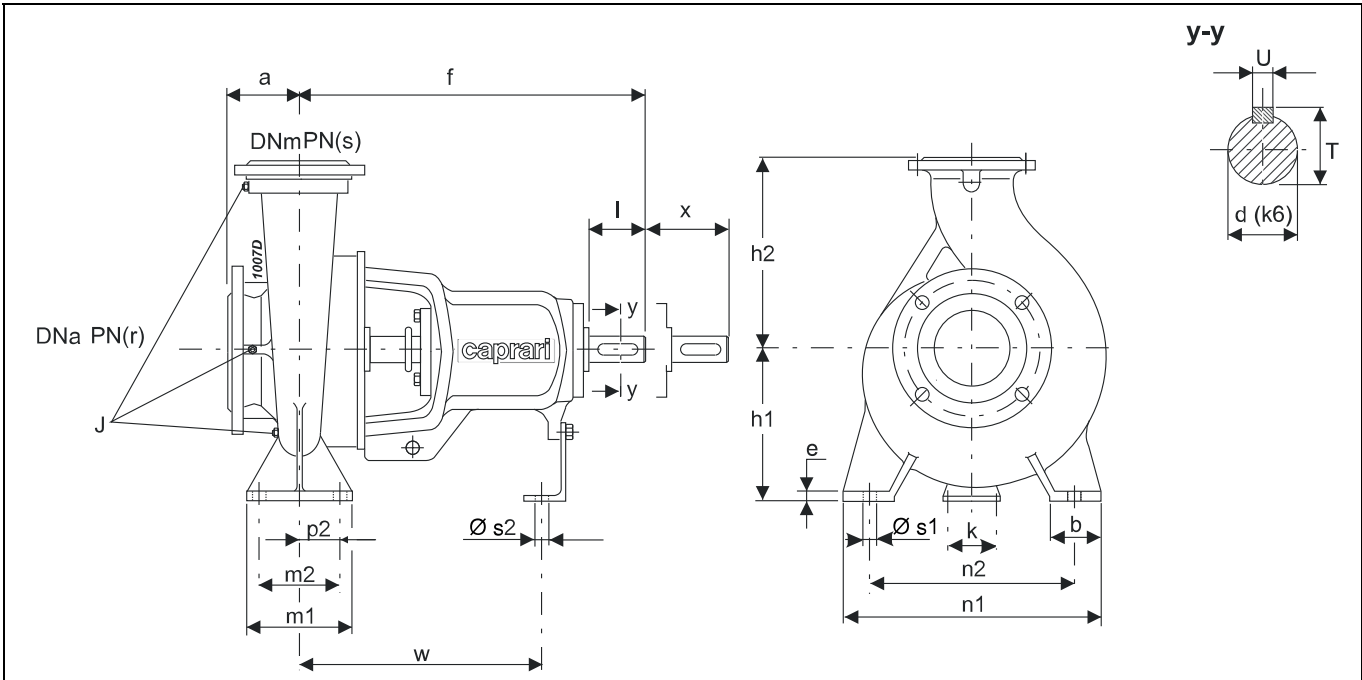

Type Тип Tipo	Dimensions pump Габариты насоса Dimensioni pompa										Duck foot pedestal dimensions Размеры опорных ножек Dimensioni piedi di appoggio								Shaft projection Выступ вала Sporgenza d'albero						Plugs Залушки Tappi	Weight Вес Peso
	DNa	DNm	r	s	a	f	h1	h2	b	e	m1	m2	p2	n1	n2	k	w	s1	s2	d	l	T	U	X	J	[kg]
	[mm]																									
NC32-250	50	32	16	16	100	360	180	225	65	14	125	95	-	320	250	110	260	ø 14	ø 14	24	50	27	8	100	G1/4.G3/8x2.G1/4	59
NC40-250	65	40	16	16	100	360	180	225	65	14	125	95	-	320	250	110	260	ø 14	ø 14	24	50	27	8	100	G1/4.G3/8x2.G1/4	61
NC40-315	65	40	16	16	125	470	200	225	65	14	125	95	-	345	280	110	340	ø 14	ø 14	32	80	35	10	100	G1/4.G3/8x2.G1/4	96
NC50-125	65	50	16	16	100	360	132	160	50	14	100	70	-	240	190	100	260	ø 14	ø 14	24	50	27	8	100	G1/4x2.G3/8.G1/4	34
NC50-200	65	50	16	16	100	360	160	200	50	14	100	70	-	265	212	110	260	ø 14	ø 14	24	50	27	8	100	G1/4.G3/8x2.G1/4	46
NC50-250	65	50	16	16	100	360	180	225	65	14	125	95	-	320	250	110	260	ø 14	ø 14	24	50	27	8	100	G1/4.G3/8x2.G1/4	71
NC50-315	65	50	16	16	125	470	225	280	65	16	125	95	-	345	280	110	340	ø 14	ø 14	32	80	35	10	100	G1/4.G3/8x2.G1/4	101
NCH50-315	80	50	16	25	125	500	225	280	65	18	125	95	-	345	280	110	370	ø 14	ø 14	32	80	35	10	100	G1/4x3	87
NC65-160	80	65	16	16	100	360	160	200	65	14	125	95	-	280	212	110	260	ø 14	ø 14	24	50	27	8	100	G1/4.G3/8x2.G1/4	43
NC65-200	80	65	16	16	100	360	180	225	65	14	125	95	-	320	250	110	260	ø 14	ø 14	24	50	27	8	100	G1/4.G3/8x2.G1/4	52
NC65-250	80	65	16	16	100	470	200	250	80	16	160	120	-	360	280	110	340	ø 18	ø 14	32	80	35	10	100	G1/4.G3/8x2.G1/4	81
NC65-315	80	65	16	16	125	470	225	280	80	16	160	120	-	400	315	110	340	ø 18	ø 14	32	80	35	10	100	G1/4.G3/8x2.G1/4	110
NCH65-315	100	65	16	16	125	530	225	280	80	18	160	120	-	400	315	110	370	ø 18	ø 14	42	110	45	12	140	G1/4x3	118
NC80-200	100	80	16	16	125	470	180	250	65	14	125	95	-	345	280	110	340	ø 14	ø 14	32	80	35	10	100	G1/4.G3/8x2.G1/4	75
NC80-250	100	80	16	16	125	470	200	280	80	16	160	120	-	400	315	110	340	ø 18	ø 14	32	80	35	10	100	G1/4.G3/8x2.G1/4	91
NC80-315	100	80	16	16	125	470	250	315	80	16	160	120	-	400	315	110	340	ø 18	ø 14	32	80	35	10	100	G3/8x3.G3/8	120
NC80-400	100	80	16	16	125	532	280	355	85	16	160	120	-	440	340	110	370	ø 18	ø 14	42	110	45	12	140	G3/8x2.G1/2.G1/4	161
NC100-200	125	100	16	16	125	470	200	280	80	16	160	120	-	360	280	110	340	ø 18	ø 14	32	80	35	10	140	G3/8x3.G1/4	85
NC100-315	125	100	16	16	140	470	250	315	80	16	160	120	-	400	315	110	340	ø 18	ø 14	32	80	35	10	140	G3/8x3.G3/8	134
NC100-400	125	100	16	16	140	530	280	355	100	18	200	150	-	500	400	110	370	ø 23	ø 14	42	110	45	12	140	G3/8x2.G1/2.G1/4	174
NCH100-315	125	100	16	16	140	530	250	315	80	19	160	120	-	400	315	110	370	ø 18	ø 14	42	110	45	12	140	G1/4x3	135
NC125-200	150	125	16	16	140	470	250	315	80	16	160	120	-	400	315	110	340	ø 18	ø 14	32	80	35	10	140	G3/8x3.G3/8	106
NC125-250	150	125	16	16	140	470	250	355	80	16	160	120	-	400	315	110	340	ø 18	ø 14	32	80	35	10	140	G3/8x3.G3/8	125
NC125-315	150	125	16	16	140	530	280	355	100	18	200	150	-	500	400	110	370	ø 23	ø 14	42	110	45	12	140	G3/8x2.G1/2.G1/4	163
NC125-400	150	125	16	16	140	530	315	400	100	18	200	150	-	500	400	110	370	ø 23	ø 14	42	110	45	12	140	G3/8x2.G1/2.G1/4	191
NCH125-250	150	125	16	16	140	530	250	355	80	19	160	120	-	400	315	110	370	ø 18	ø 14	42	110	45	12	140	G1/4x3	140
NCH125-400	150	125	16	16	140	530	315	400	100	21	200	150	-	500	400	110	370	ø 18	ø 14	42	110	45	12	140	G1/4x3	186
NCH125-500	150	125	16	16	160	670	355	450	100	25	200	150	-	550	450	140	500	ø 23	ø 18	48	110	51,5	14	180	G1/4x3	359
NC150-250	200	150	16	16	160	530	250	355	100	18	200	150	-	450	350	110	370	ø 23	ø 14	42	110	45	12	140	G1/4.G3/8x2.G1/2.G3/8	148

Overall dimensions and weights
 Общие габариты и вес
 Dimensioni di ingombro e pesi

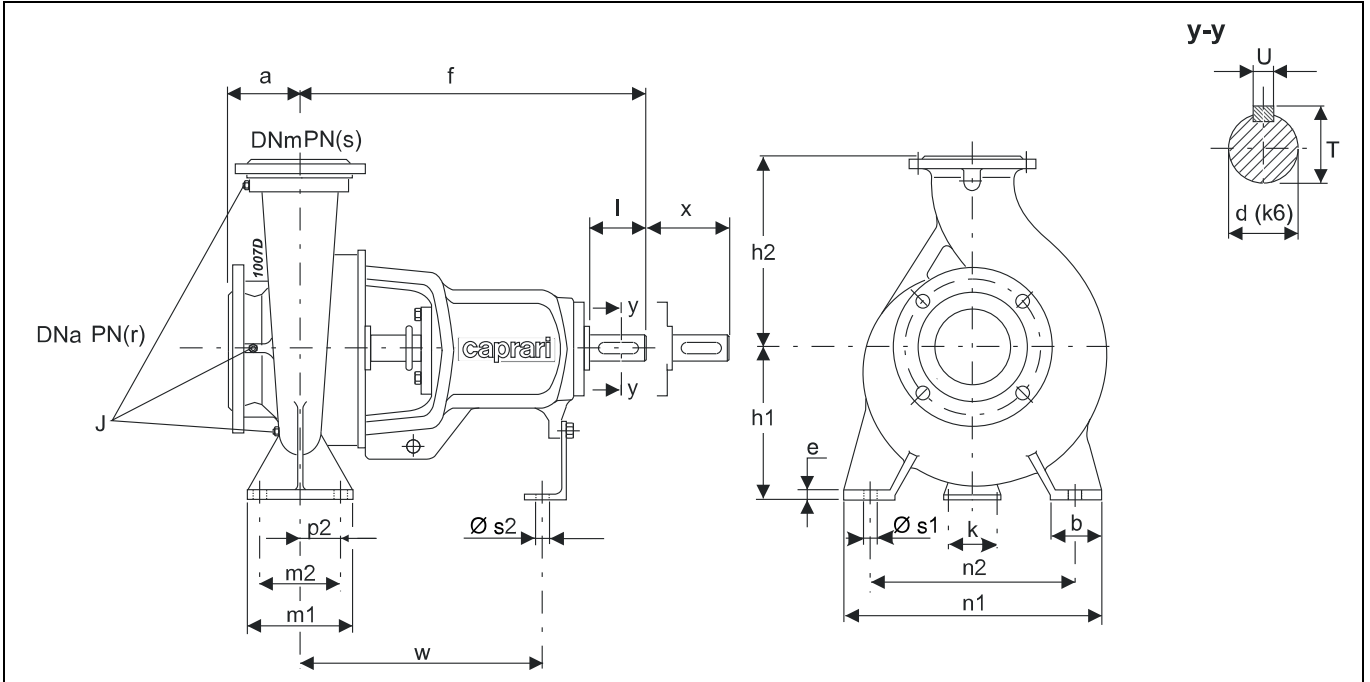

Type Тип Tipo	Dimensions pump Габариты насоса Dimensioni pompa							Duck foot pedestal dimensions Размеры опорных ножек Dimensioni piedi di appoggio										Shaft projection Выступ вала Sporgenza d'albero					Plugs Заглушки Tappi	Weight Вес Peso				
	DNa	DNm	r	s	a	f	h1	h2	b	e	m1	m2	p2	n1	n2	k	w	s1	s2	d	l	T	U	X	J			
	[mm]																											
NC150-315	200	150	16	16	160	530	280	400	100	18	200	150	-	550	450	110	370	ø 23	ø 14	42	110	45	12	140	G1/4x3	170		
NC150-400	200	150	16	16	160	530	315	450	100	18	200	150	-	550	450	110	370	ø 23	ø 14	42	110	45	12	140	G3/8x2 G1/2. G1/4	209		
NCH150-500	200	150	16	16	160	670	400	500	100	25	200	150	60	550	450	140	480	ø 23	ø 18	60	140	64	18	180	G3/8x3	410		
NC200-400	250	200	16	16	180	670	335	480	120	20	220	170	-	600	480	110	504	ø 28	ø 14	48	110	51	14	180	G3/8x3, G3/8	295		
NCH200-500	250	200	16	16	225	885	400	580	150	28	315	250	-	760	630	180	670	ø 28	ø 18	65	140	69	18	250	G3/8x3	577		

Selection - dimensions and weights for base mounted electric pumps
 Подбор - габариты и вес электронасосов на раме
 Selezione - dimensioni e pesi elettropompe su base

COUPLINGS WITH STANDARDIZED ENCLOSED ELECTRIC MOTORS
 СОЕДИНЕНИЕ С НОРМАЛИЗОВАННЫМИ ЗАКРЫТЫМИ ЭЛЕКТРОДВИГАТЕЛЯМИ
 ACCORPIAMENTI CON MOTORI ELETTRICI CHIUSI NORMALIZZATI

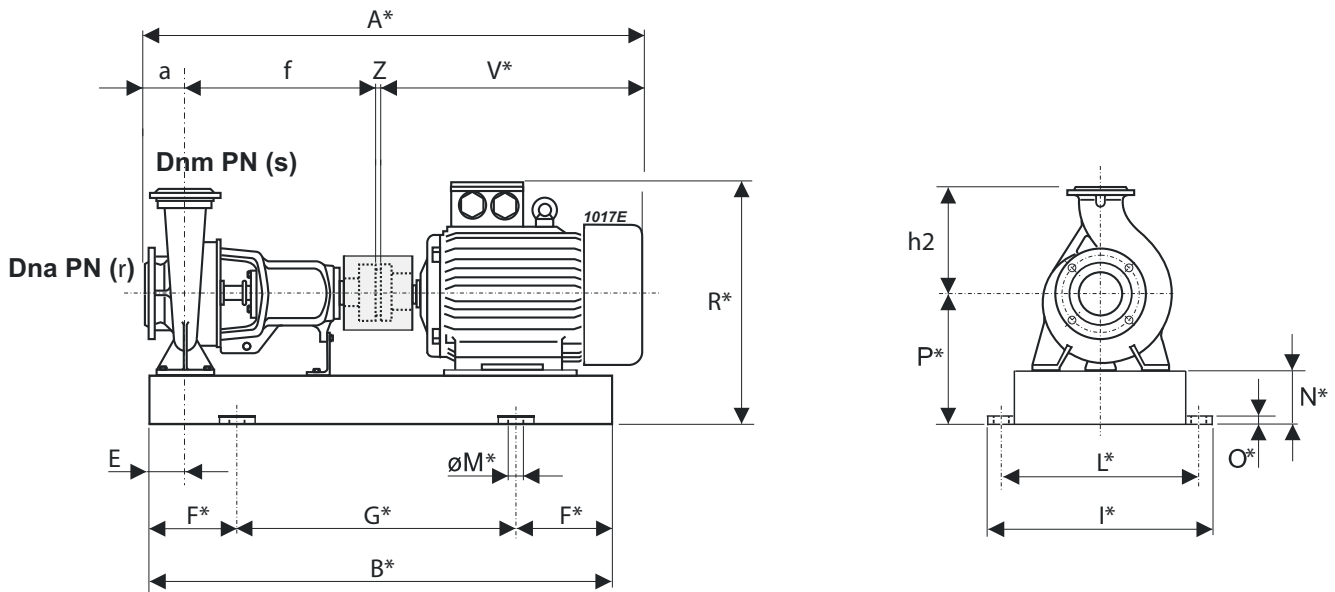

* Valori indicativi in funzione della marca di motore utilizzato - Indicatives values according to the type of motor installed - Приблизительные значения в зависимости от марки двигателя

Pump Насос Pompa		Motor Двигатель Motore		BGAN	A*	B*	E	F*	G*	I*	L*	M*	N*	O*	P*	R*	V*	Z	a	f	h2	r	s	Weight Вес Peso	
Type Тип Tipo	DNa	DNm	[kW]	Size Размер Grand.	Type Тип Tipo	[mm]																			[kg]
NC32-250	50	32	11	160M	1014/DA	1091	909,5	72,5	150	609,5	450	400	∅ 20	100	42	280	531	627	4	100	360	225	16	16	239
NC32-250	50	32	15	160M	1014/DA	1091	909,5	72,5	150	609,5	450	400	∅ 20	100	42	280	531	627	4	100	360	225	16	16	250
NC32-250	50	32	18,5	160L	1015/DA	1091	953,5	72,5	150	653,5	450	400	∅ 20	100	42	280	531	627	4	100	360	225	16	16	252
NC40-250	65	40	11	160M	1014/DA	1091	909,5	72,5	150	609,5	450	400	∅ 20	100	42	280	531	627	4	100	360	225	16	16	241
NC40-250	65	40	15	160M	1014/DA	1091	909,5	72,5	150	609,5	450	400	∅ 20	100	42	280	531	627	4	100	360	225	16	16	252
NC40-250	65	40	18,5	160L	1015/DA	1091	953,5	72,5	150	653,5	450	400	∅ 20	100	42	280	531	627	4	100	360	225	16	16	254
NC40-250	65	40	22	180M	1016/EA	1129	963,5	72,5	150	663,5	500	450	∅ 20	100	42	280	550	665	4	100	360	225	16	16	305
NC40-250	65	40	30	200L	1017/FA	1202	1061,5	97,5	200	661,5	540	490	∅ 20	100	42	300	600	738	4	100	360	225	16	16	356
NC40-250	65	40	37	200L	1017/FA	1202	1061,5	97,5	200	661,5	540	490	∅ 20	100	42	300	600	738	4	100	360	225	16	16	384
NC50-125	65	50	2,2	90L	1004/CA	849	690	60	100	490	370	320	∅ 16	65	38	197	335	385	4	100	360	160	16	16	73
NC50-125	65	50	3	100L	1005/CA	869	724,5	60	100	524,5	370	320	∅ 16	65	38	197	347	405	4	100	360	160	16	16	80
NC50-125	65	50	4	112M	1121/CA	904	732	60	100	532	370	320	∅ 16	65	38	197	369	440	4	100	360	160	16	16	82
NC50-125	65	50	5,5	132S	1122/CA	919	773	60	150	473	405	355	∅ 16	65	38	197	389	455	4	100	360	160	16	16	95
NC50-200	65	50	11	160M	1013/DA	1091	897	60	150	597	465	415	∅ 16	80	38	240	491	627	4	100	360	200	16	16	211
NC50-200	65	50	15	160M	1013/DA	1091	897	60	150	597	465	415	∅ 16	80	38	240	491	627	4	100	360	200	16	16	222
NC50-200	65	50	18,5	160L	1155/CA	1091	941	60	150	641	465	415	∅ 16	80	38	240	491	627	4	100	360	200	16	16	214
NC50-250	65	50	18,5	160L	1015/DA	1091	953,5	72,5	150	653,5	450	400	∅ 20	100	42	280	531	627	4	100	360	225	16	16	264
NC50-250	65	50	22	180M	1016/EA	1129	963,5	72,5	150	663,5	500	450	∅ 20	100	42	280	550	665	4	100	360	225	16	16	315
NC50-250	65	50	30	200L	1017/FA	1202	1061,5	97,5	200	661,5	540	490	∅ 20	100	42	300	600	738	4	100	360	225	16	16	366
NC50-250	65	50	37	200L	1017/FA	1202	1061,5	97,5	200	661,5	540	490	∅ 20	100	42	300	600	738	4	100	360	225	16	16	394

BGAN = Base and coupling
 * = Indicatives values according to the type of motor installed.

BGAMA = Рама и муфта
 * = Приблизит. значения в зависимости от марки двигателя.

BGAN = Base e giunto
 * = Valori indicativi in funzione della marca di motore utilizzato.

COUPLINGS WITH STANDARDIZED ENCLOSED ELECTRIC MOTORS
 СОЕДИНЕНИЕ С НОРМАЛИЗОВАННЫМИ ЗАКРЫТЫМИ ЭЛЕКТРОДВИГАТЕЛЯМИ
 ACCOPPIAMENTI CON MOTORI ELETTRICI CHIUSI NORMALIZZATI

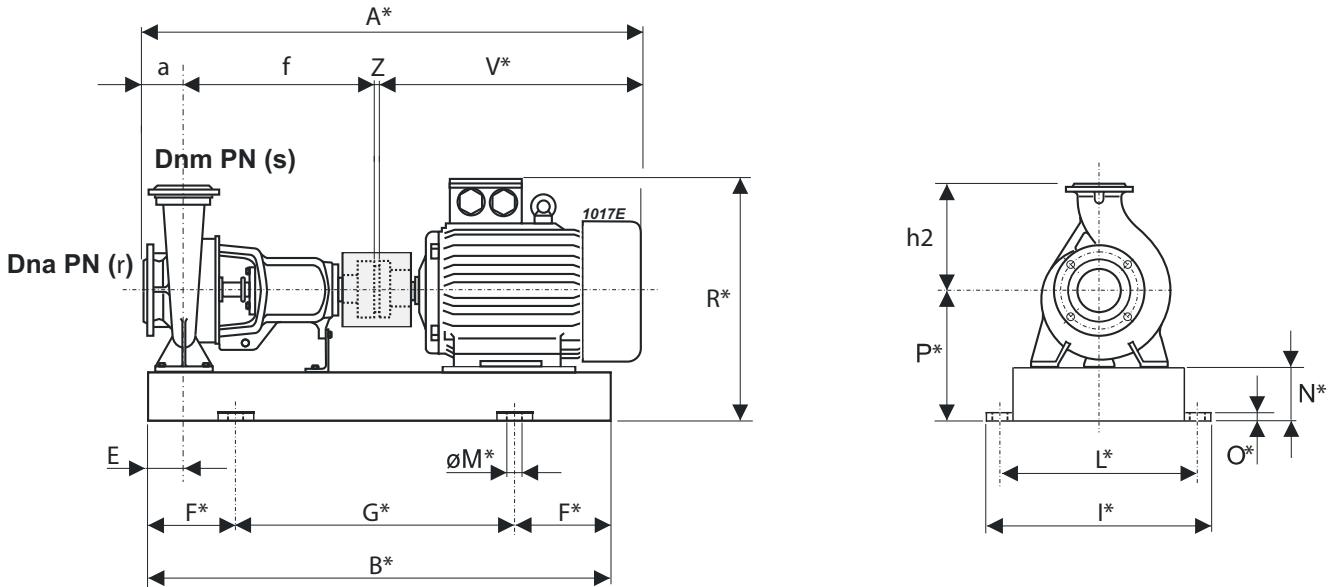

* Valori indicativi in funzione della marca di motore utilizzato - Indicatives values according to the type of motor installed - Приблизительные значения в зависимости от марки двигателя

Pump Насос Помпа	DNa [mm]	DNm [mm]	Motor Двигатель Motore [kW]	Size Размер Grand.	BGAN	A	B	E	F	G	I	L	M	N	O	P	R	V	Z	a	f	h2	r	s	Weight Вес Peso
						[mm]	[mm]	[mm]	[mm]	[mm]	[mm]	[mm]	[mm]	[mm]	[mm]	[mm]	[mm]	[mm]	[mm]	[mm]	[mm]	[mm]	[mm]	[mm]	[mm]
NCH50-315	80	50	22	180M	2000/EX	1294	1103,5	72,5	200	703,5	500	450	ø 20	120	42	345	615	665	4	125	500	280	16	25	338
NCH50-315	80	50	30	200L	2001/FX	1367	1176,5	72,5	200	776,5	540	490	ø 20	120	42	345	645	738	4	125	500	280	16	25	397
NCH50-315	80	50	37	200L	2001/FX	1367	1176,5	72,5	200	776,5	540	490	ø 20	120	42	345	645	738	4	125	500	280	16	25	425
NCH50-315	80	50	45	225M	2002/FX	1404	1202,5	72,5	200	802,5	585	535	ø 20	120	42	345	675	775	4	125	500	280	16	25	485
NCH50-315	80	50	55	250M	2003/GX	1499	1319,5	97,5	200	919,5	635	585	ø 20	120	42	370	745	870	4	125	500	280	16	25	659
NCH50-315	80	50	75	280S	2004/HX	1629	1379	100	250	879	695	645	ø 20	140	42	420	815	1000	4	125	500	280	16	25	777
NCH50-315	80	50	90	280M	2005/HX	1680	1430	100	250	930	695	645	ø 20	140	42	420	815	1051	4	125	500	280	16	25	852
NC65-160	80	65	7,5	132S	1019/CA	919	785,5	72,5	150	485,5	410	360	ø 16	80	38	240	432	455	4	100	360	200	16	16	109
NC65-160	80	65	11	160M	1020/DA	1091	909,5	72,5	150	609,5	465	415	ø 16	80	38	240	491	627	4	100	360	200	16	16	191
NC65-160	80	65	15	160M	1020/DA	1091	909,5	72,5	150	609,5	465	415	ø 16	80	38	240	491	627	4	100	360	200	16	16	202
NC65-160	80	65	18,5	160L	1123/DA	1091	953,5	72,5	150	653,5	465	415	ø 16	80	38	240	491	627	4	100	360	200	16	16	227
NC65-200	80	65	11	160M	1014/DA	1091	909,5	72,5	150	609,5	450	400	ø 20	100	42	280	531	627	4	100	360	225	16	16	232
NC65-200	80	65	15	160M	1014/DA	1091	909,5	72,5	150	609,5	450	400	ø 20	100	42	280	531	627	4	100	360	225	16	16	243
NC65-200	80	65	18,5	160L	1015/DA	1091	953,5	72,5	150	653,5	450	400	ø 20	100	42	280	531	627	4	100	360	225	16	16	245
NC65-200	80	65	22	180M	1016/EA	1129	963,5	72,5	150	663,5	500	450	ø 20	100	42	280	550	665	4	100	360	225	16	16	296
NC65-200	80	65	30	200L	1017/FA	1202	1061,5	97,5	200	661,5	540	490	ø 20	100	42	300	600	738	4	100	360	225	16	16	347
NC65-200	80	65	37	200L	1017/FA	1202	1061,5	97,5	200	661,5	540	490	ø 20	100	42	300	600	738	4	100	360	225	16	16	375
NC65-250	80	65	30	200L	1021/FX	1312	1164	90	200	764	540	490	ø 20	100	42	300	600	738	4	100	470	250	16	16	392
NC65-250	80	65	37	200L	1021/FX	1312	1164	90	200	764	540	490	ø 20	100	42	300	600	738	4	100	470	250	16	16	420
NC65-250	80	65	45	225M	1022/FX	1349	1220	120	200	820	585	535	ø 20	120	42	345	675	775	4	100	470	250	16	16	510
NC65-250	80	65	55	250M	1032/GX	1444	1312	120	200	912	635	585	ø 20	120	42	370	745	870	4	100	470	250	16	16	555
NC65-250	80	65	75	280S	1125/HX	1574	1369	120	250	869	695	645	ø 20	140	42	420	815	1000	4	100	470	250	16	16	781
NCH65-315	100	65	37	200L	2006/FX	1397	1224	90	200	824	530	480	ø 20	120	42	345	645	738	4	125	530	280	16	16	457
NCH65-315	100	65	45	225M	2007/FX	1434	1250	90	200	850	585	535	ø 20	120	42	345	675	775	4	125	530	280	16	16	516
NCH65-315	100	65	55	250M	2008/GX	1529	1372	120	250	872	635	585	ø 20	120	42	370	745	870	4	125	530	280	16	16	615
NCH65-315	100	65	75	280S	2009/HX	1659	1439	130	250	939	695	645	ø 20	140	42	420	815	1000	4	125	530	280	16	16	811
NCH65-315	100	65	90	280M	2010/HX	1710	1490	130	250	990	695	645	ø 20	140	42	420	815	1051	4	125	530	280	16	16	886
NCH65-315	100	65	110	315S	2011/HX	1840	1536	130	250	1036	780	730	ø 22	160	50	475	1030	1181	4	125	530	280	16	16	987
NCH65-315	100	65	132	315M	2012/HX	1950	1646	130	250	1146	780	730	ø 22	160	50	475	1030	1291	4	125	530	280	16	16	991
NCH65-315	100	65	160	315L	2012/IX	1950	1646	130	250	1146	780	730	ø 22	160	50	475	1030	1291	4	125	530	280	16	16	1469
NC80-200	100	80	15	160M	1023/DX	1226	1019,5	72,5	150	719,5	475	425	ø 20	100	42	280	531	627	4	125	470	250	16	16	257
NC80-200	100	80	18,5	160L	1024/DX	1226	1063,5	72,5	200	663,5	475	425	ø 20	100	42	280	531	627	4	125	470	250	16	16	270
NC80-200	100	80	22	180M	1025/EX	1264	1073,5	72,5	200	673,5	500	450	ø 20	100	42	280	550	665	4	125	470	250	16	16	324
NC80-200	100	80	30	200L	1026/FX	1337	1171,5	97,5	200	771,5	540	490	ø 20	100	42	300	600	738	4	125	470	250	16	16	362

BGAN = Base and coupling

* = Indicatives values according to the type of motor installed.

BGAMA = Рама и муфта

* = Приблизит. значения в зависимости от марки двигателя.

BGAN = Base e giunto

* = Valori indicativi in funzione della marca di motore utilizzato.

Motor in IE4 efficiency class according to EU REGULATION 2019/1781. Available in other efficiency classes for non-EU markets.

Двигатель класса эффективности IE4 в соответствии с РЕГУЛАЦИЕЙ ЕС 2019/1781. Доступны другие классы эффективности для рынков за пределами ЕС.

Motore in classe di efficienza IE4 in conformità al REGOLAMENTO UE2019/1781. Disponibili in altre classi di efficienza per mercati extra UE.

Selection - dimensions and weights for base mounted electric pumps
Подбор - габариты и вес электронасосов на раме
Selezione - dimensioni e pesi elettropompe su base

COUPLINGS WITH STANDARDIZED ENCLOSED ELECTRIC MOTORS
СОЕДИНЕНИЕ С НОРМАЛИЗОВАННЫМИ ЗАКРЫТЫМИ ЭЛЕКТРОДВИГАТЕЛЯМИ
ACCOPPIAMENTI CON MOTORI ELETTRICI CHIUSI NORMALIZZATI

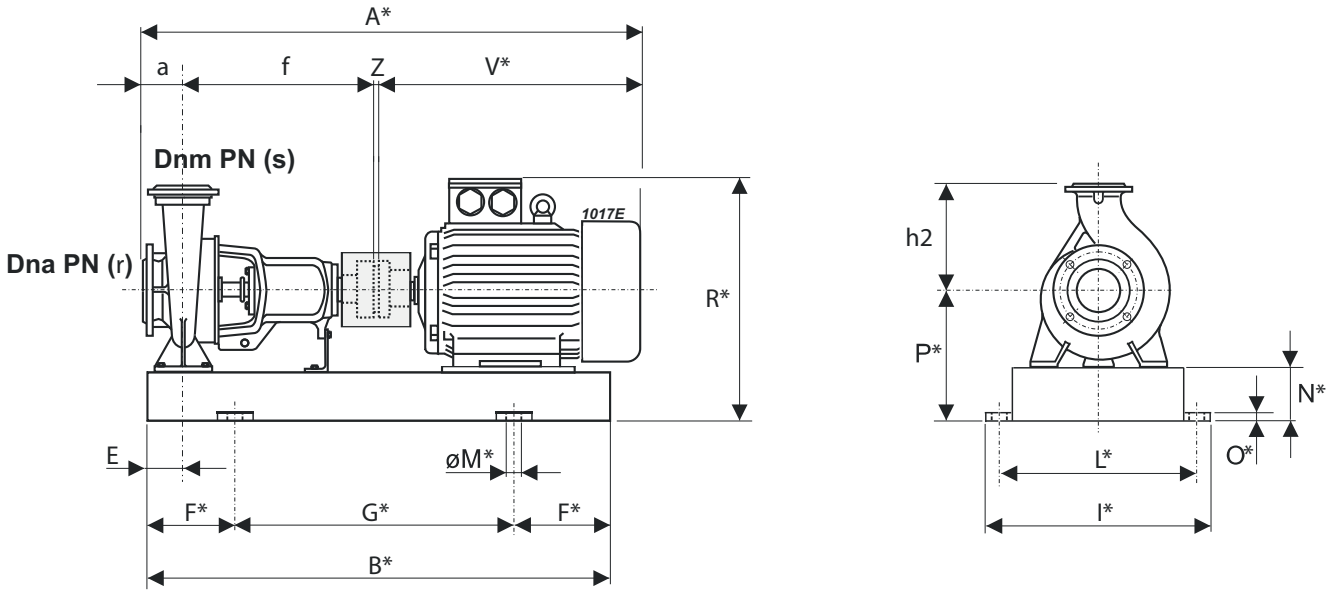

* Valori indicativi in funzione della marca di motore utilizzato - Indicatives values according to the type of motor installed - Приблизительные значения в зависимости от марки двигателя

Pump Насос Pompa		Motor Двигатель Motore		BGAN	A*	B*	E	F*	G*	I*	L*	M*	N*	O*	P*	R*	V*	Z	a	f	h2	r	s	Weight Вес Peso	
Type Тип Tipo	DNa [mm]	DNm [mm]	[kW]	Size Размер Grand.	Type Тип Tipo	[mm]																			[kg]
NC80-200	100	80	37	200L	1026/FX	1337	1171,5	97,5	200	771,5	540	490	ø 20	100	42	300	600	738	4	125	470	250	16	16	390
NC80-200	100	80	45	225M	1124/FX	1374	1197,5	97,5	200	797,5	585	535	ø 20	120	42	345	675	775	4	125	470	250	16	16	482
NC80-250	100	80	37	200L	1027/FX	1337	1164	90	200	764	530	480	ø 20	100	42	300	600	738	4	125	470	280	16	16	416
NC80-250	100	80	45	225M	1028/FX	1374	1220	120	200	820	585	535	ø 20	120	42	345	675	775	4	125	470	280	16	16	469
NC80-250	100	80	55	250M	1029/GX	1469	1312	120	200	912	635	585	ø 20	120	42	370	745	870	4	125	470	280	16	16	565
NC80-250	100	80	75	280S	1030/HX	1599	1369	120	250	869	695	645	ø 20	140	42	420	815	1000	4	125	470	280	16	16	713
NC100-200	125	100	22	180M	1031/EX	1264	1091	90	200	691	490	440	ø 20	100	42	300	570	665	4	125	470	280	16	16	325
NC100-200	125	100	30	200L	1021/FX	1337	1164	90	200	764	540	490	ø 20	100	42	300	600	738	4	125	470	280	16	16	396
NC100-200	125	100	37	200L	1021/FX	1337	1164	90	200	764	540	490	ø 20	100	42	300	600	738	4	125	470	280	16	16	424
NC100-200	125	100	45	225M	1022/FX	1374	1220	120	200	820	585	535	ø 20	120	42	345	675	775	4	125	470	280	16	16	514
NC100-200	125	100	55	250M	1032/GX	1469	1312	120	200	912	635	585	ø 20	120	42	370	745	870	4	125	470	280	16	16	559
NC100-200	125	100	75	280S	1125/HX	1599	1369	120	250	869	695	645	ø 20	140	42	420	815	1000	4	125	470	280	16	16	785
NCH100-315	125	100	55	250M	2013/GX	1544	1342	90	200	942	635	585	ø 20	120	42	370	745	870	4	140	530	315	16	16	629
NCH100-315	125	100	75	280S	2014/HX	1674	1419	120	250	919	695	645	ø 20	140	42	420	815	1000	4	140	530	315	16	16	817
NCH100-315	125	100	90	280M	2015/HX	1725	1470	120	250	970	695	645	ø 20	140	42	420	815	1051	4	140	530	315	16	16	893
NCH100-315	125	100	110	315S	2016/HX	1855	1536	130	250	1036	780	730	ø 22	160	50	475	1030	1181	4	140	530	315	16	16	883
NCH100-315	125	100	132	315M	2017/HX	1965	1646	130	250	1146	780	730	ø 22	160	50	475	1030	1291	4	140	530	315	16	16	961
NCH100-315	125	100	160	315L	2017/IX	1965	1646	130	250	1146	780	730	ø 22	160	50	475	1030	1291	4	140	530	315	16	16	1375
NCH100-315	125	100	200	315L	2017/IE4/LX	2055	1736	130	300	1136	780	730	ø 22	160	50	475	1030	1381	4	140	530	315	16	16	1560
NC125-200	150	125	55	250M	1094/GX	1484	1282	90	200	882	635	585	ø 20	120	42	370	745	870	4	140	470	315	16	16	598
NC125-200	150	125	75	280S	1095/HE	1614	1359	120	250	859	695	645	ø 20	140	42	420	815	1000	4	140	470	315	16	16	787
NC125-200	150	125	90	280M	1107/HE	1665	1410	120	250	910	695	645	ø 20	140	42	420	815	1051	4	140	470	315	16	16	862
NCH125-250	150	125	55	250M	2013/GX	1544	1342	90	200	942	635	585	ø 20	120	42	370	745	870	4	140	530	355	16	16	634
NCH125-250	150	125	75	280S	2014/HX	1674	1419	120	250	919	695	645	ø 20	140	42	420	815	1000	4	140	530	355	16	16	822
NCH125-250	150	125	90	280M	2015/HX	1725	1470	120	250	970	695	645	ø 20	140	42	420	815	1051	4	140	530	355	16	16	898
NCH125-250	150	125	110	315S	2016/HX	1855	1536	130	250	1036	780	730	ø 22	160	50	475	1030	1181	4	140	530	355	16	16	888
NCH125-250	150	125	132	315M	2017/HX	1965	1646	130	250	1146	780	730	ø 22	160	50	475	1030	1291	4	140	530	355	16	16	966
NCH125-250	150	125	160	315L	2017/IX	1965	1646	130	250	1146	780	730	ø 22	160	50	475	1030	1291	4	140	530	355	16	16	1380
NCH125-250	150	125	200	315L	2017/IE4/LX	2055	1736	130	300	1136	780	730	ø 22	160	50	475	1030	1381	4	140	530	355	16	16	1565

BGAN = Base and coupling
* = Indicatives values according to the type of motor installed.

BGAMA = Рама и муфта
* = Приблизит. значения в зависимости от марки двигателя.

BGAN = Base e giunto
* = Valori indicativi in funzione della marca di motore utilizzato.

o Motor in IE4 efficiency class according to EU REGULATION 2019/1781. Available in other efficiency classes for non-EU markets.

o Двигатель класса эффективности IE4 в соответствии с РЕГЛАМЕНТОМ ЕС 2019/1781. Доступны другие классы эффективности для рынков за пределами ЕС.

o Motore in classe di efficienza IE4 in conformità al REGOLAMENTO UE2019/1781. Disponibili in altre classi di efficienza per mercati extra UE.

Selection - dimensions and weights for base mounted electric pumps
 Подбор - габариты и вес электронасосов на раме
 Selezione - dimensioni e pesi elettropompe su base

COUPLINGS WITH STANDARDIZED ENCLOSED ELECTRIC MOTORS
 СОЕДИНЕНИЕ С НОРМАЛИЗОВАННЫМИ ЗАКРЫТЫМИ ЭЛЕКТРОДВИГАТЕЛЯМИ
 ACCORPIAMENTI CON MOTORI ELETTRICI CHIUSI NORMALIZZATI

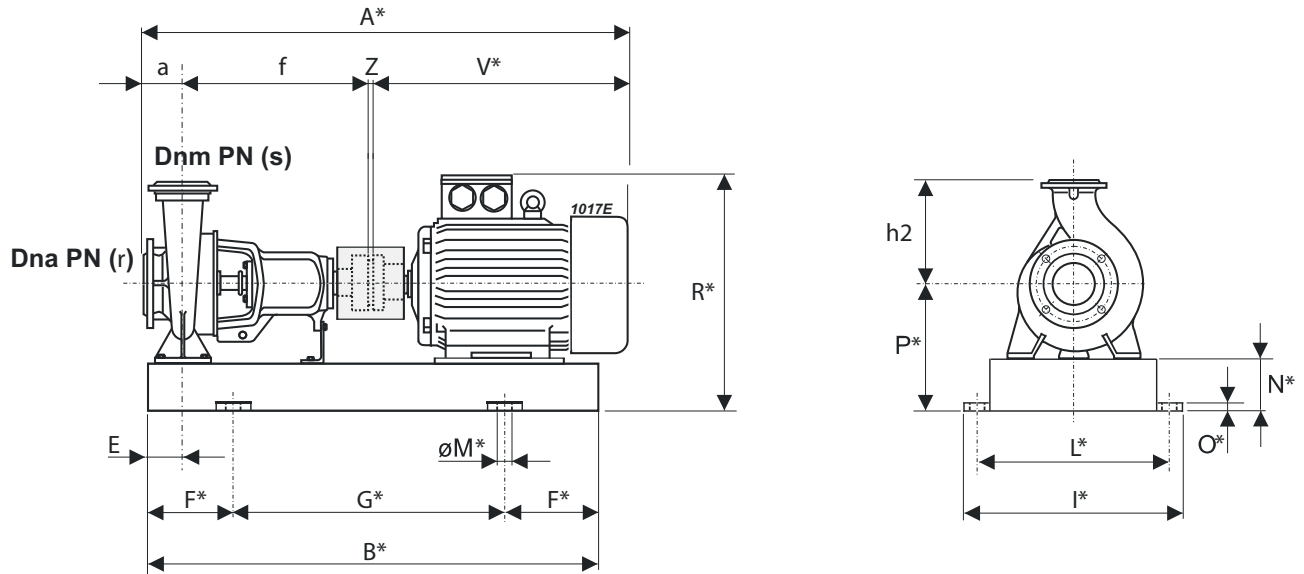

* Valori indicativi in funzione della marca di motore utilizzato - Indicatives values according to the type of motor installed - Приблизительные значения в зависимости от марки двигателя

Pump Насос Pompa		Motor Двигатель Motore		BGAN	A*	B*	E	F*	G*	I*	L*	M*	N*	O*	P*	R*	V*	Z	a	f	h2	r	s	Weight Вес Peso	
Type Тип Tipo	DNa [mm]	DNm [mm]	[kW]	Size Размер Grand.	Type Тип Tipo	[mm]																			[kg]
NC32-250	50	32	2,2	100L	1050/CA	869	737	72,5	100	537	450	400	ø 20	100	42	280	430	405	4	100	360	225	16	16	131
NC32-250	50	32	3	100L	1050/CA	869	737	72,5	100	537	450	400	ø 20	100	42	280	430	405	4	100	360	225	16	16	135
NC32-250	50	32	4	112M	1051/CA	904	744,5	72,5	100	544,5	450	400	ø 20	100	42	280	452	440	4	100	360	225	16	16	131
NC40-250	65	40	2,2	100L	1050/CA	869	737	72,5	100	537	450	400	ø 20	100	42	280	430	405	4	100	360	225	16	16	133
NC40-250	65	40	3	100L	1050/CA	869	737	72,5	100	537	450	400	ø 20	100	42	280	430	405	4	100	360	225	16	16	137
NC40-250	65	40	4	112M	1051/CA	904	744,5	72,5	100	544,5	450	400	ø 20	100	42	280	452	440	4	100	360	225	16	16	133
NC40-315	65	40	4	112M	1053/DX	1039	854,5	72,5	150	554,5	475	425	ø 20	100	42	300	472	440	4	125	470	225	16	16	178
NC40-315	65	40	5,5	132S	1054/DX	1054	895,5	72,5	150	595,5	475	425	ø 20	100	42	300	492	455	4	125	470	225	16	16	185
NC40-315	65	40	7,5	132M	1055/DX	1089	933,5	72,5	150	633,5	475	425	ø 20	100	42	300	492	490	4	125	470	225	16	16	195
NC40-315	65	40	11	160M	1056/EX	1226	1019,5	72,5	150	719,5	475	425	ø 20	100	42	300	551	627	4	125	470	225	16	16	270
NC50-125	65	50	0,75	80M	1040/CA	759	659	60	100	459	370	320	ø 16	65	38	197	322	295	4	100	360	160	16	16	24306
NC50-200	65	50	1,1	90S	1048/CA	819	665	60	100	465	395	345	ø 16	80	38	240	378	355	4	100	360	200	16	16	91
NC50-200	65	50	1,5	90L	1049/CA	849	690	60	100	490	395	345	ø 16	80	38	240	378	385	4	100	360	200	16	16	96
NC50-200	65	50	2,2	100L	1052/CA	869	724,5	60	100	524,5	395	345	ø 16	80	38	240	390	405	4	100	360	200	16	16	107
NC50-250	65	50	2,2	100L	1050/CA	869	737	72,5	100	537	450	400	ø 20	100	42	280	430	405	4	100	360	225	16	16	143
NC50-250	65	50	3	100L	1050/CA	869	737	72,5	100	537	450	400	ø 20	100	42	280	430	405	4	100	360	225	16	16	147
NC50-250	65	50	4	112M	1051/CA	904	744,5	72,5	100	544,5	450	400	ø 20	100	42	280	452	440	4	100	360	225	16	16	143
NC50-315	65	50	4	112M	1132/DX	1039	854,5	72,5	150	554,5	475	425	ø 20	120	42	345	517	440	4	125	470	280	16	16	195
NC50-315	65	50	5,5	132S	1133/DX	1054	895,5	72,5	150	595,5	475	425	ø 20	120	42	345	537	455	4	125	470	280	16	16	201
NC50-315	65	50	7,5	132M	1134/DX	1089	933,5	72,5	150	633,5	475	425	ø 20	120	42	345	537	490	4	125	470	280	16	16	211
NC50-315	65	50	11	160M	1135/EX	1226	1029,5	72,5	150	729,5	475	425	ø 20	120	42	345	596	627	4	125	470	280	16	16	325
NC65-160	80	65	0,75	80M	1057/CA	759	661,5	72,5	100	461,5	410	360	ø 16	80	38	240	365	295	4	100	360	200	16	16	88
NC65-160	80	65	1,1	90S	1153/CA	819	677,5	72,5	100	477,5	410	360	ø 16	80	38	240	378	355	4	100	360	200	16	16	89
NC65-160	80	65	1,5	90L	1059/CA	849	702,5	72,5	100	502,5	410	360	ø 16	80	38	240	378	385	4	100	360	200	16	16	94
NC65-160	80	65	2,2	100L	1060/CA	869	737	72,5	100	537	410	360	ø 16	80	38	240	390	405	4	100	360	200	16	16	100
NC65-200	80	65	1,5	90L	1061/CA	849	702,5	72,5	100	502,5	450	400	ø 20	100	42	280	418	385	4	100	360	225	16	16	110
NC65-200	80	65	2,2	100L	1050/CA	869	737	72,5	100	537	450	400	ø 20	100	42	280	430	405	4	100	360	225	16	16	124
NC65-200	80	65	3	100L	1050/CA	869	737	72,5	100	537	450	400	ø 20	100	42	280	430	405	4	100	360	225	16	16	128
NC65-250	80	65	4	112M	1051/CA	904	744,5	72,5	100	544,5	450	400	ø 20	100	42	280	452	440	4	100	360	225	16	16	124
NC65-250	80	65	3	100L	1062/DX	979	864,5	90	150	564,5	490	440	ø 20	100	42	300	450	405	4	100	470	250	16	16	163
NC65-250	80	65	4	112M	1063/DX	1014	872	90	150	572	490	440	ø 20	100	42	300	472	440	4	100	470	250	16	16	164
NC65-250	80	65	5,5	132S	1064/DX	1029	913	90	150	613	490	440	ø 20	100	42	300	492	455	4	100	470	250	16	16	174
NC65-250	80	65	7,5	132M	1065/DX	1064	951	90	150	651	490	440	ø 20	100	42	300	492	490	4	100	470	250	16	16	183
NC65-315	80	65	5,5	132S	1066/DX	1054	913	90	150	613	530	480	ø 20	120	42	345	537	455	4	125	470	280	16	16	215
NC65-315	80	65	7,5	132M	1067/DX	1089	951	90	150	651	530	480	ø 20	120	42	345	537	490	4	125	470	280	16	16	225
NC65-315	80	65	11	160M	1068/EX	1226	1047	90	150	747	530	480	ø 20	120	42	345	596	627	4	125	470	280	16	16	308
NC65-315	80	65	15	160L	1069/EX	1226	1091	90	200	691	530	480	ø 20	120	42	345	596	627	4	125	470	280	16	16	318

BGAN = Base and coupling
 * = Indicatives values according to the type of motor installed.

BGAMA = Рама и муфта
 * = Приблизит. значения в зависимости от марки двигателя.

BGAN = Base e giunto
 * = Valori indicativi in funzione della marca di motore utilizzato.

Selection - dimensions and weights for base mounted electric pumps
 Подбор - габариты и вес электронасосов на раме
 Selezione - dimensioni e pesi elettropompe su base

COUPLINGS WITH STANDARDIZED ENCLOSED ELECTRIC MOTORS
 СОЕДИНЕНИЕ С НОРМАЛИЗОВАННЫМИ ЗАКРЫТЫМИ ЭЛЕКТРОДВИГАТЕЛЯМИ
 ACCOPPIAMENTI CON MOTORI ELETTRICI CHIUSI NORMALIZZATI

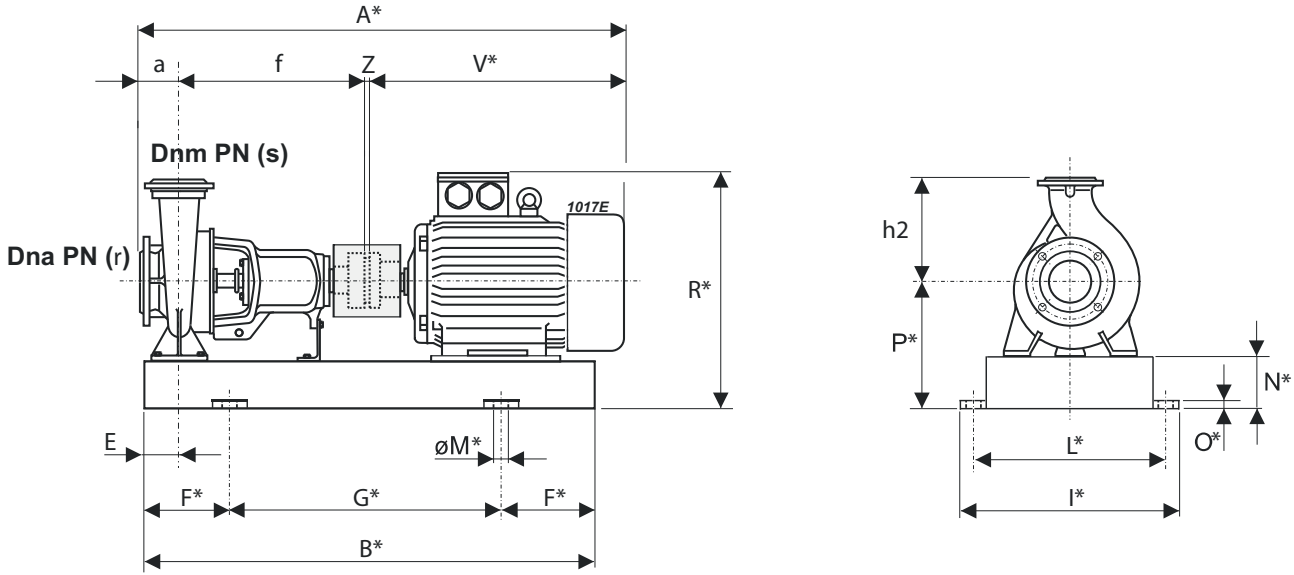

* Valori indicativi in funzione della marca di motore utilizzato - Indicatives values according to the type of motor installed - Приблизительные значения в зависимости от марки двигателя

Pump Насос Pompa		Motor Двигатель Motore		BGAN	A *	B *	E	F *	G *	I *	L *	M *	N *	O *	P *	R *	V *	Z	a	f	h2	r	s	Weight Вес Peso	
Type Тип Tipo	DNa [mm]	DNm [mm]	[kW] kW	Size Размер Grand.	Type Тип Tipo	[mm]																			[kg]
NC80-200	100	80	2,2	100L	1071/DX	1004	847	72,5	150	547	475	425	ø 20	100	42	280	430	405	4	125	470	250	16	16	150
NC80-200	100	80	3	100L	1071/DX	1004	847	72,5	150	547	475	425	ø 20	100	42	280	430	405	4	125	470	250	16	16	154
NC80-200	100	80	4	112M	1072/DX	1039	854,5	72,5	150	554,5	475	425	ø 20	100	42	280	452	440	4	125	470	250	16	16	156
NC80-200	100	80	5,5	132S	1073/DX	1054	895,5	72,5	150	595,5	475	425	ø 20	100	42	280	472	455	4	125	470	250	16	16	165
NC80-200	100	80	7,5	132M	1074/DX	1089	933,5	72,5	150	633,5	475	425	ø 20	100	42	280	472	490	4	125	470	250	16	16	174
NC80-250	100	80	5,5	132S	1075/DX	1054	913	90	150	613	530	480	ø 20	100	42	300	492	455	4	125	470	280	16	16	185
NC80-250	100	80	7,5	132M	1076/DX	1089	951	90	150	651	530	480	ø 20	100	42	300	492	490	4	125	470	280	16	16	197
NC80-250	100	80	11	160M	1077/EX	1226	1037	90	150	737	530	480	ø 20	100	42	300	551	627	4	125	470	280	16	16	282
NC80-250	100	80	15	160L	1078/EX	1226	1081	90	200	681	530	480	ø 20	100	42	300	551	627	4	125	470	280	16	16	301
NC80-315	100	80	7,5	132M	1079/DX	1089	951	90	150	651	530	480	ø 20	120	42	370	562	490	4	125	470	315	16	16	237
NC80-315	100	80	11	160M	1080/EX	1226	1047	90	150	747	530	480	ø 20	120	42	370	621	627	4	125	470	315	16	16	326
NC80-315	100	80	15	160L	1081/EX	1226	1091	90	200	691	530	480	ø 20	120	42	370	621	627	4	125	470	315	16	16	320
NC80-315	100	80	18,5	180M	1082/FX	1264	1101	90	200	701	530	480	ø 20	120	42	370	640	665	4	125	470	315	16	16	375
NC80-400	100	80	18,5	180M	1091/FY	1326	1163	90	200	763	570	520	ø 20	140	42	420	690	665	4	125	532	355	16	16	479
NC80-400	100	80	22	180L	1092/FY	1366	1201	90	200	801	570	520	ø 20	140	42	420	690	705	4	125	532	355	16	16	500
NC80-400	100	80	30	200L	1093/GY	1419	1236	90	200	836	570	520	ø 20	140	42	420	720	758	4	125	532	355	16	16	510
NC100-200	125	100	3	100L	1062/DX	1004	864,5	90	150	564,5	490	440	ø 20	100	42	300	450	405	4	125	470	280	16	16	167
NC100-200	125	100	4	112M	1063/DX	1039	872	90	150	572	490	440	ø 20	100	42	300	472	440	4	125	470	280	16	16	168
NC100-200	125	100	5,5	132S	1064/DX	1054	913	90	150	613	490	440	ø 20	100	42	300	492	455	4	125	470	280	16	16	178
NC100-200	125	100	7,5	132M	1065/DX	1089	951	90	150	651	490	440	ø 20	100	42	300	492	490	4	125	470	280	16	16	187
NC100-315	125	100	11	160M	1080/EX	1241	1047	90	150	747	530	480	ø 20	120	42	370	621	627	4	140	470	315	16	16	340
NC100-315	125	100	15	160L	1081/EX	1241	1091	90	200	691	530	480	ø 20	120	42	370	621	627	4	140	470	315	16	16	334
NC100-315	125	100	18,5	180M	1082/FX	1279	1101	90	200	701	530	480	ø 20	120	42	370	640	665	4	140	470	315	16	16	389
NC100-315	125	100	22	180L	1083/FX	1319	1139	90	200	739	530	480	ø 20	120	42	370	640	705	4	140	470	315	16	16	420

BGAN = Base and coupling
 * = Indicatives values according to the type of motor installed.

BGAMA = Рама и муфта
 * = Приблизит. значения в зависимости от марки двигателя.

BGAN = Base e giunto
 * = Valori indicativi in funzione della marca di motore utilizzato.

Selection - dimensions and weights for base mounted electric pumps
 Подбор - габариты и вес электронасосов на раме
 Selezione - dimensioni e pesi elettropompe su base

COUPLINGS WITH STANDARDIZED ENCLOSED ELECTRIC MOTORS
 СОЕДИНЕНИЕ С НОРМАЛИЗОВАННЫМИ ЗАКРЫТЫМИ ЭЛЕКТРОДВИГАТЕЛЯМИ
 ACCOPPIAMENTI CON MOTORI ELETTRICI CHIUSI NORMALIZZATI

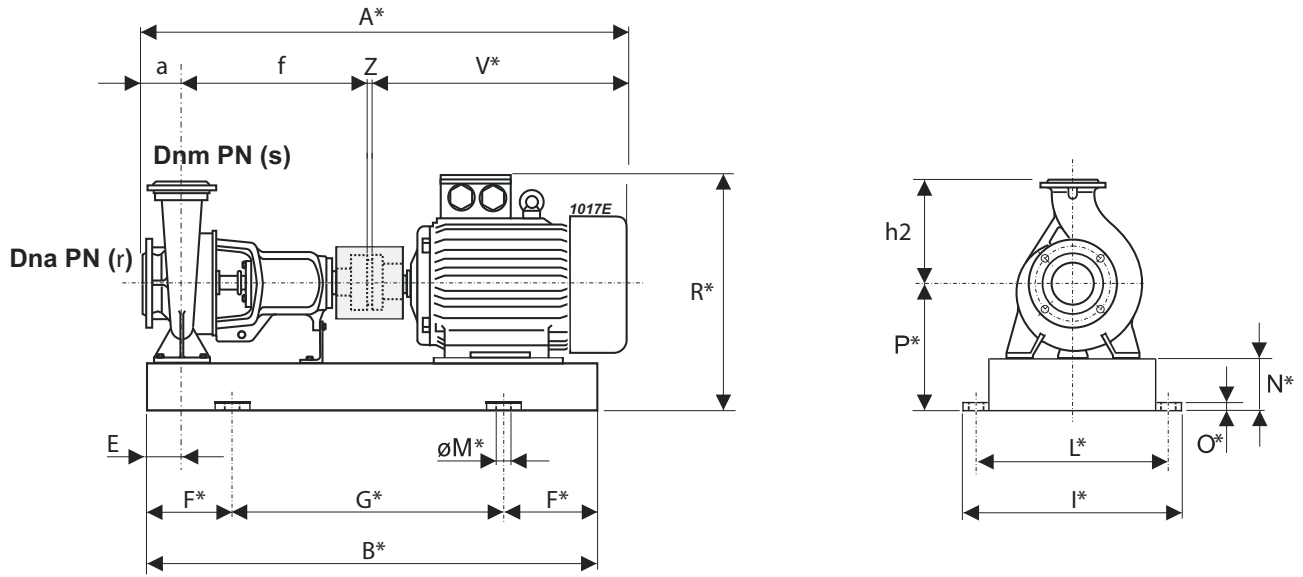

* Valori indicativi in funzione della marca di motore utilizzato - Indicatives values according to the type of motor installed - Приблизительные значения в зависимости от марки двигателя

Pump Насос Pompa		Motor Двигатель Motore		BGAN	A*	B*	E	F*	G*	I*	L*	M*	N*	O*	P*	R*	V*	Z	a	f	h2	r	s	Weight Вес Peso	
Type Тип Tipo	DNa [mm]	DNm [mm]	[kW] kW	Size Размер Grand.	Type Тип Tipo	[mm]																			[kg]
NC100-400	125	100	22	180L	1084/FY	1379	1219	110	200	819	630	580	ø 20	140	42	420	690	705	4	140	530	355	16	16	450
NC100-400	125	100	30	200L	1085/GY	1432	1254	110	200	854	630	580	ø 20	140	42	420	720	758	4	140	530	355	16	16	534
NC100-400	125	100	37	225S	1086/GY	1467	1275	110	200	875	630	580	ø 20	140	42	420	750	793	4	140	530	355	16	16	618
NC100-400	125	100	45	225M	1087/HY	1492	1300	110	200	900	630	580	ø 20	140	42	420	750	818	4	140	530	355	16	16	660
NC100-400	125	100	55	250M	1088/HY	1554	1362	110	250	862	630	580	ø 20	140	42	420	795	880	4	140	530	355	16	16	748
NC125-200	150	125	7,5	132M	1079/DX	1104	951	90	150	651	530	480	ø 20	120	42	370	562	490	4	140	470	315	16	16	223
NC125-200	150	125	11	160M	1080/EX	1241	1047	90	150	747	530	480	ø 20	120	42	370	621	627	4	140	470	315	16	16	312
NC125-200	150	125	15	160L	1081/EX	1241	1091	90	200	691	530	480	ø 20	120	42	370	621	627	4	140	470	315	16	16	306
NC125-200	150	125	18,5	180M	1082/FX	1279	1101	90	200	701	530	480	ø 20	120	42	370	640	665	4	140	470	315	16	16	361
NC125-200	150	125	22	180L	1083/FX	1319	1139	90	200	739	530	480	ø 20	120	42	370	640	705	4	140	470	315	16	16	392
NC125-250	150	125	11	160M	1080/EX	1241	1047	90	150	747	530	480	ø 20	120	42	370	621	627	4	140	470	355	16	16	331
NC125-250	150	125	15	160L	1081/EX	1241	1091	90	200	691	530	480	ø 20	120	42	370	621	627	4	140	470	355	16	16	325
NC125-250	150	125	18,5	180M	1082/FX	1279	1101	90	200	701	530	480	ø 20	120	42	370	640	665	4	140	470	355	16	16	380
NC125-250	150	125	22	180L	1083/FX	1319	1139	90	200	739	530	480	ø 20	120	42	370	640	705	4	140	470	355	16	16	411
NC125-315	150	125	15	160L	1090/EY	1301	1171	110	200	771	630	580	ø 20	140	42	420	671	627	4	140	530	355	16	16	481
NC125-315	150	125	18,5	180M	1154/FY	1339	1181	110	200	781	630	580	ø 20	140	42	420	690	665	4	140	530	355	16	16	494
NC125-315	150	125	22	180L	1084/FY	1379	1219	110	200	819	630	580	ø 20	140	42	420	690	705	4	140	530	355	16	16	439
NC125-315	150	125	30	200L	1085/GY	1432	1254	110	200	854	630	580	ø 20	140	42	420	720	758	4	140	530	355	16	16	523
NC125-315	150	125	37	225S	1086/GY	1467	1275	110	200	875	630	580	ø 20	140	42	420	750	793	4	140	530	355	16	16	607
NC125-315	150	125	45	225M	1087/HY	1492	1300	110	200	900	630	580	ø 20	140	42	420	750	818	4	140	530	355	16	16	649
NC125-400	150	125	45	225M	1096/HY	1492	1310	110	200	910	630	580	ø 22	160	50	475	805	818	4	140	530	400	16	16	676
NC125-400	150	125	55	250M	1097/HY	1554	1362	110	250	862	630	580	ø 22	160	50	475	850	880	4	140	530	400	16	16	831
NC125-400	150	125	75	280S	1098/IY	1687	1409	110	250	909	695	645	ø 22	160	50	475	870	1013	4	140	530	400	16	16	977
NCH125-400	150	125	22	180L	2046/FY3	1379	1209	110	200	809	630	580	ø 22	160	50	475	745	705	4	140	530	400	16	16	487
NCH125-400	150	125	30	200L	2048/GY3	1432	1282	110	200	882	630	580	ø 22	160	50	475	775	758	4	140	530	400	16	16	550
NCH125-400	150	125	37	225S	2050/GY3	1467	1285	110	200	885	630	580	ø 22	160	50	475	805	793	4	140	530	400	16	16	638
NCH125-400	150	125	45	225M	2049/HY4	1492	1310	110	200	910	630	580	ø 22	160	50	475	805	818	4	140	530	400	16	16	682
NCH125-400	150	125	55	250M	2051/HY4	1554	1362	110	250	862	630	580	ø 22	160	50	475	850	880	4	140	530	400	16	16	779
NCH125-400	150	125	75	280S	2057/LY4	1687	1409	110	250	909	695	645	ø 22	160	50	475	870	1013	4	140	530	400	16	16	905
NCH125-400	150	125	90	280M	2052/IY4	1738	1460	110	250	960	695	645	ø 22	160	50	475	870	1064	4	140	530	400	16	16	966
NCH125-500	150	125	55	250M	2033/HY4	1714	1512	110	250	1012	680	630	ø 22	180	50	535	910	880	4	160	670	450	16	16	976
NCH125-500	150	125	75	280S	2035/IY4	1847	1559	110	250	1059	680	630	ø 22	180	50	535	930	1013	4	160	670	450	16	16	1123
NCH125-500	150	125	90	280M	2036/IY4	1898	1610	110	250	1110	680	630	ø 22	180	50	535	930	1064	4	160	670	450	16	16	1189
NCH125-500	150	125	110	315S	2025/LY4	2045	1666	110	300	1066	780	730	ø 22	180	50	535	1090	1211	4	160	670	450	16	16	1486
NCH125-500	150	125	132	315M	2037/LY4	2155	1725	110	300	1125	780	730	ø 22	180	50	535	1090	1321	4	160	670	450	16	16	1614

BGAN = Base and coupling
 * = Indicatives values according to the type of motor installed.

BGAMA = Рама и муфта
 * = Приблизит. значения в зависимости от марки двигателя.

BGAN = Base e giunto
 * = Valori indicativi in funzione della marca di motore utilizzato.

Motor in IE4 efficiency class according to EU REGULATION 2019/1781. Available in other efficiency classes for non-EU markets.

Двигатель класса эффективности IE4 в соответствии с РЕГУЛАЦИОННОМ ЕС 2019/1781. Доступны другие классы эффективности для рынков за пределами ЕС.

Motore in classe di efficienza IE4 in conformità al REGOLAMENTO UE2019/1781. Disponibili in altre classi di efficienza per mercati extra UE.

Selection - dimensions and weights for base mounted electric pumps
Подбор - габариты и вес электронасосов на раме
Selezione - dimensioni e pesi elettropompe su base

COUPLINGS WITH STANDARDIZED ENCLOSED ELECTRIC MOTORS
СОЕДИНЕНИЕ С НОРМАЛИЗОВАННЫМИ ЗАКРЫТЫМИ ЭЛЕКТРОДВИГАТЕЛЯМИ
ACCORRIAMENTI CON MOTORI ELETTRICI CHIUSI NORMALIZZATI

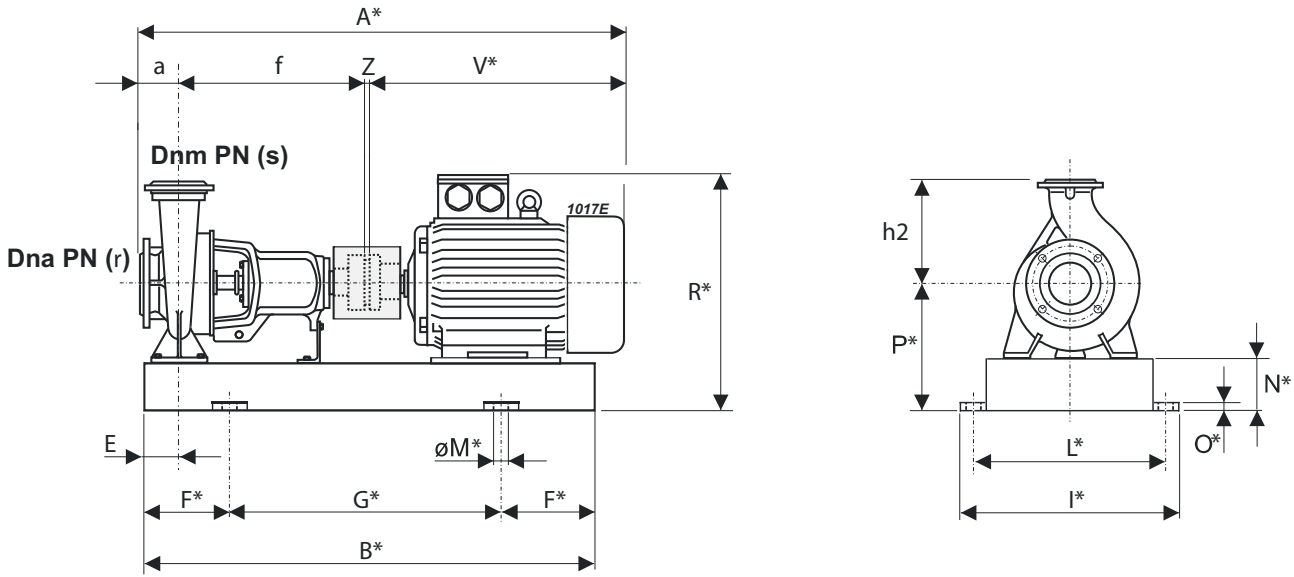

* Valori indicativi in funzione della marca di motore utilizzato - Indicatives values according to the type of motor installed - Приблизительные значения в зависимости от марки двигателя

Pump Насос Ромпа	Motor Двигатель Motore		BGAN	A *	B *	E	F *	G *	I *	L *	M *	N *	O *	P *	R *	V *	Z	a	f	h2	r	s	Weight Вес Peso		
	Type Тип Tipo	DNa [mm]																						DNm [mm]	[kW]
NCH125-500	150	125	160	315L	2037/MY5	2155	1776	110	300	1176	780	730	ø 22	180	50	535	1090	1321	4	160	670	450	16	16	1709
NC150-250	200	150	18,5	180M	1136/FY	1359	1181	110	200	781	580	530	ø 20	120	42	370	640	665	4	160	530	355	16	16	425
NC150-250	200	150	22	180L	1137/FY	1399	1219	110	200	819	580	530	ø 20	120	42	370	640	705	4	160	530	355	16	16	446
NC150-250	200	150	30	200L	1151/GY	1452	1244	110	200	844	580	530	ø 20	120	42	370	670	758	4	160	530	355	16	16	502
NC150-315	200	150	22	180L	1138/FY	1399	1219	110	200	819	680	630	ø 20	140	42	420	690	705	4	160	530	400	16	16	532
NC150-315	200	150	30	200L	1100/GX	1452	1254	110	200	854	680	630	ø 20	140	42	420	720	758	4	160	530	400	16	16	491
NC150-315	200	150	37	225S	1101/GX	1487	1275	110	200	875	680	630	ø 20	140	42	420	750	793	4	160	530	400	16	16	623
NC150-315	200	150	45	225M	1102/HY	1512	1300	110	200	900	680	630	ø 20	140	42	420	750	818	4	160	530	400	16	16	636
NC150-315	200	150	55	250M	1103/HY	1574	1362	110	250	862	680	630	ø 20	140	42	420	795	880	4	160	530	400	16	16	817
NC150-400	200	150	45	225M	1139/HY	1512	1310	110	200	910	680	630	ø 22	160	50	475	805	818	4	160	530	450	16	16	729
NC150-400	200	150	55	250M	1140/HY	1574	1362	110	250	862	680	630	ø 22	160	50	475	850	880	4	160	530	450	16	16	808
NC150-400	200	150	75	280S	1104/IY	1707	1409	110	250	909	680	630	ø 22	160	50	475	870	1013	4	160	530	450	16	16	965
NC150-400	200	150	90	280M	1105/IY	1758	1460	110	250	960	680	630	ø 22	160	50	475	870	1064	4	160	530	450	16	16	1122
NC150-400	200	150	110	315S	1106/LY	1905	1536	110	250	1036	780	730	ø 22	160	50	475	1030	1211	4	160	530	450	16	16	1309
NCH150-500	200	150	45	225M	2018/GY2	1652	1521	127	250	1021	680	630	ø 22	200	50	600	930	818	4	160	670	500	16	16	976
NCH150-500	200	150	55	250M	2019/HY2	1714	1578	127	250	1078	680	630	ø 22	200	50	600	975	880	4	160	670	500	16	16	1083
NCH150-500	200	150	75	280S	2020/IY2	1847	1576	127	250	1076	680	630	ø 22	200	50	600	995	1013	4	160	670	500	16	16	1296
NCH150-500	200	150	90	280M	2021/IY2	1898	1627	127	250	1127	680	630	ø 22	200	50	600	995	1064	4	160	670	500	16	16	1257
NCH150-500	200	150	110	315S	2022/LY2	2045	1703	127	300	1103	780	730	ø 22	200	50	600	1155	1211	4	160	670	500	16	16	1573
NCH150-500	200	150	132	315M	2023/MY2	2155	1813	127	300	1213	780	730	ø 22	200	50	600	1155	1321	4	160	670	500	16	16	1645
NCH150-500	200	150	160	315L	2023/MY2	2155	1813	127	300	1213	780	730	ø 22	200	50	600	1155	1321	4	160	670	500	16	16	1740
NCH150-500	200	150	200	315L	2023/IE4/MY2	2245	1916	127	300	1316	780	730	ø 22	200	50	600	1155	1411	4	160	670	500	16	16	1950
NC200-400	250	200	75	280S	1116/IY2	1867	1584	145	250	1084	730	680	ø 22	160	50	495	890	1013	4	180	670	480	16	16	1067
NC200-400	250	200	90	280M	1117/IY2	1918	1635	145	250	1135	730	680	ø 22	160	50	495	890	1064	4	180	670	480	16	16	1175
NC200-400	250	200	110	315S	1118/LY2	2065	1711	145	300	1111	780	730	ø 22	160	50	495	1050	1211	4	180	670	480	16	16	1350
NC200-400	250	200	132	315M	1120/LY2	2175	1770	145	300	1170	780	730	ø 22	160	50	495	1050	1321	4	180	670	480	16	16	1510
NCH200-500	250	200	90	280M	2027/IY4	2178	1885	170	300	1285	890	840	ø 22	200	50	600	995	1064	4	225	885	580	16	16	1498
NCH200-500	250	200	110	315S	2028/LY4	2325	1961	170	350	1261	890	840	ø 22	200	50	600	1155	1211	4	225	885	580	16	16	1801
NCH200-500	250	200	132	315M	2029/LY4	2435	2071	170	350	1371	890	840	ø 22	200	50	600	1155	1321	4	225	885	580	16	16	1930
NCH200-500	250	200	160	315L	2029/MY5	2435	2071	170	350	1371	890	840	ø 22	200	50	600	1155	1321	4	225	885	580	16	16	2025
NCH200-500	250	200	200	315L	2029/IE4/MY5	2525	2161	170	350	1461	890	840	ø 22	200	50	600	1155	1411	4	225	885	580	16	16	2150
NCH200-500	250	200	250	355M	2026/NY5	2670	2215	170	350	1515	890	840	ø 22	200	50	600	1201	1556	4	225	885	580	16	16	2442
NCH200-500	250	200	315	355L	2026/PY5	2670	2215	170	350	1515	890	840	ø 22	200	50	600	1201	1556	4	225	885	580	16	16	2632

BGAN = Base and coupling
* = Indicatives values according to the type of motor installed.

BGAMA = Рама и муфта
* = Приблизит. значения в зависимости от марки двигателя.

BGAN = Base e giunto
* = Valori indicativi in funzione della marca di motore utilizzato.

o Motor in IE4 efficiency class according to EU REGULATION 2019/1781. Available in other efficiency classes for non-EU markets.

o Двигатель класса эффективности IE4 в соответствии с РЕГЛАМЕНТОМ ЕС 2019/1781. Доступны другие классы эффективности для рынков за пределами ЕС.

o Motore in classe di efficienza IE4 in conformità al REGOLAMENTO UE2019/1781. Disponibili in altre classi di efficienza per mercati extra UE.

Selection - dimensions and weights for base mounted electric pumps
 Подбор - габариты и вес электронасосов на раме
 Selezione - dimensioni e pesi elettropompe su base

COUPLINGS WITH STANDARDIZED ENCLOSED ELECTRIC MOTORS
 СОЕДИНЕНИЕ С НОРМАЛИЗОВАННЫМИ ЗАКРЫТЫМИ ЭЛЕКТРОДВИГАТЕЛЯМИ
 ACCORPIAMENTI CON MOTORI ELETTRICI CHIUSI NORMALIZZATI

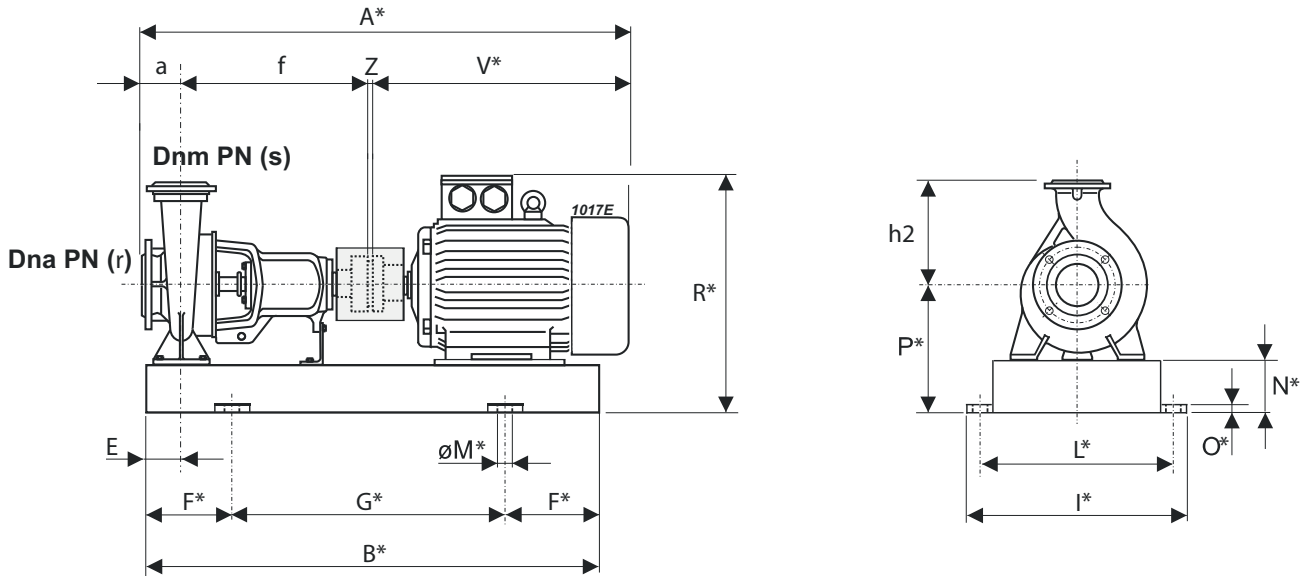

* Valori indicativi in funzione della marca di motore utilizzato - Indicatives values according to the type of motor installed - Приблизительные значения в зависимости от марки двигателя

Pump Насос Ромпа	Motor Двигатель Motore		BGAN	A *	B *	E	F *	G *	I *	L *	M *	N *	O *	P *	R *	V *	Z	a	f	h2	r	s	Weight Вес Peso		
Type Тип Tipo	DNa [mm]	DNm [kW]	Size Размер Grand.	Type Тип Tipo	[mm]																		[kg]		
NCH125-400	150	125	11	160L	2045/EY3	1301	1161	110	200	761	630	580	∅ 22	160	50	475	726	627	4	140	530	400	16	16	428
NCH125-400	150	125	15	180L	2046/FY3	1379	1209	110	200	809	630	580	∅ 22	160	50	475	745	705	4	140	530	400	16	16	482
NCH125-400	150	125	18,5	200L	2048/FY3	1432	1282	110	200	882	630	580	∅ 22	160	50	475	775	758	4	140	530	400	16	16	524
NCH125-400	150	125	22	200L	2048/GY3	1432	1282	110	200	882	630	580	∅ 22	160	50	475	775	758	4	140	530	400	16	16	540
NCH125-400	150	125	30	225M	2049/HY4	1492	1310	110	200	910	630	580	∅ 22	160	50	475	805	818	4	140	530	400	16	16	659
NCH125-500	150	125	15	180L	2038/FY3	1539	1404	110	250	904	680	630	∅ 22	180	50	535	805	705	4	160	670	450	16	16	700
NCH125-500	150	125	18,5	200L	2039/FY3	1592	1442	110	250	942	680	630	∅ 22	180	50	535	835	758	4	160	670	450	16	16	740
NCH125-500	150	125	22	200L	2039/GY3	1592	1442	110	250	942	680	630	∅ 22	180	50	535	835	758	4	160	670	450	16	16	756
NCH125-500	150	125	30	225M	2034/HY4	1652	1484	110	250	984	680	630	∅ 22	180	50	535	865	818	4	160	670	450	16	16	837
NCH125-500	150	125	37	250M	2033/HY4	1714	1512	110	250	1012	680	630	∅ 22	180	50	535	910	880	4	160	670	450	16	16	907
NCH125-500	150	125	45	280S	2035/IY4	1854	1559	110	250	1059	680	630	∅ 22	180	50	535	925	1020	4	160	670	450	16	16	1090
NCH200-500	250	200	30	225M	2031/HY4	1932	1779	170	300	1179	890	840	∅ 22	200	50	600	930	818	4	225	885	580	16	16	1103
NCH200-500	250	200	37	250M	2032/HY4	1994	1836	170	300	1236	890	840	∅ 22	200	50	600	975	880	4	225	885	580	16	16	1161
NCH200-500	250	200	45	280S	2030/IY4	2134	1834	170	300	1234	890	840	∅ 22	200	50	600	990	1020	4	225	885	580	16	16	1398
NCH200-500	250	200	55	280M	2027/IY4	2184	1885	170	300	1285	890	840	∅ 22	200	50	600	990	1070	4	225	885	580	16	16	1481
NCH200-500	250	200	75	315S	2028/LY4	2325	1961	170	350	1261	890	840	∅ 22	200	50	600	1155	1211	4	225	885	580	16	16	1996
NCH200-500	250	200	90	315M	2029/LY4	2435	2071	170	350	1371	890	840	∅ 22	200	50	600	1155	1321	4	225	885	580	16	16	2005

BGAN = Base and coupling

* = Indicatives values according to the type of motor installed.

o Motor in IE4 efficiency class according to EU REGULATION 2019/1781. Available in other efficiency classes for non-EU markets.

BGAMA = Рама и муфта

* = Приблизит. значения в зависимости от марки двигателя.

o Двигатель класса эффективности IE4 в соответствии с РЕГЛАМЕНТОМ ЕС 2019/1781. Доступны другие классы эффективности для рынков за пределами ЕС.

BGAN = Base e giunto

* = Valori indicativi in funzione della marca di motore utilizzato.

o Motore in classe di efficienza IE4 in conformità al REGOLAMENTO UE2019/1781. Disponibili in altre classi di efficienza per mercati extra UE.

Flanges (UNI EN 1092-2)
 Фланцы (UNI EN 1092-2)
 Flange (UNI EN 1092-2)

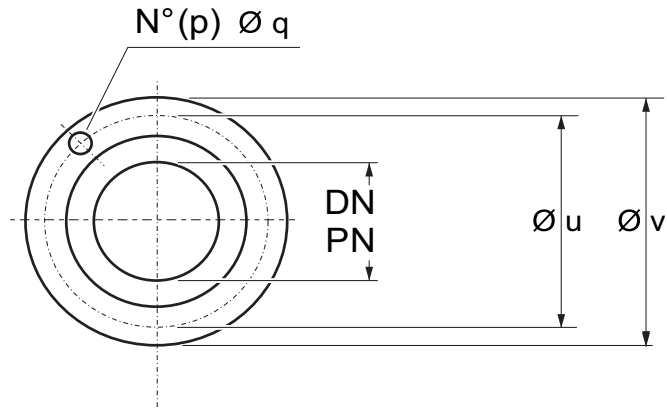

Port \varnothing <i>отверстия</i> \varnothing Восса		Holes <i>Отверстия</i> Fori		$\varnothing u$	$\varnothing v$
DN [mm]	PN [bar]	p No	q \varnothing [mm]	[mm]	
32	16	4	18	100	140
40	16	4	18	110	150
50	16	4	18	125	165
50	25	4	18	125	165
65	16	4	18	145	185
80	16	8	18	160	200
100	16	8	18	180	220
125	16	8	18	210	250
150	16	8	22	240	285
200	16	12	22	295	340
250	16	12	26	355	405
300	16	12	26	410	460

caprari

The dimensions have an indicative value. Executive drawing will be supplied on request upon order.
CAPRARI S.p.A. reserves the right to make changes to improve its products at any time and without any notice

Размеры являются ориентировочными. Чертеж будет предоставлен по запросу при заказе. CAPRARI S.p.A. оставляет за собой право вносить изменения с целью улучшения своих продуктов в любое время и без предварительного уведомления.

Le dimensioni hanno valore indicativo. Il disegno esecutivo sarà fornito su richiesta in fase d'ordine.
CAPRARI S.p.A. si riserva facoltà di apportare modifiche atte a migliorare i propri prodotti in qualsiasi momento e senza preavviso alcuno.